

ИНСТРУКЦИЯ ПО ЭКСПЛУАТАЦИИ



КОМПЛЕКТАЦИЯ:

- Детали для сборки
- Блок контроллер*
- Пульт управления**
- Стикеры
- Инструкция

*Bluetooth (IEEE 802.15.1) диапазон 2400-2483.5 МГц, мощность до 5 мВт

** диапазон 2458-2473 МГц, до 9 мВт

Необходимо докупить:

- 3 батарейки размера AAA
- 2 батарейки размера AA

Строго соблюдая полярность, установите соответствующие элементы питания в пульт управления и в контроллер модели. Выполните сборку модели любого типа согласно инструкции по сборке. Проверьте что Bluetooth на телефоне включен. Переведите переключатель ON/OFF на контроллере в положение ON.

Загрузите приложение HIPER STEM из магазина приложений вашего телефона. Найти актуальное приложение можно на странице товара на сайте www.hiper-power.com



УСЛОВИЯ ЭКСПЛУАТАЦИИ

Не допускается хранение устройства при экстремальных температурах (выше +40°C или ниже -10°C). Это может отрицательно сказаться на работоспособности.

УСЛОВИЯ ТРАНСПОРТИРОВКИ И ХРАНЕНИЯ

В упакованном виде устройство может транспортироваться в крытых транспортных средствах любого типа при температуре от -10 до +50°C с защитой от непосредственного воздействия атмосферных осадков, солнечного излучения и механических повреждений. Допускается использовать и хранить устройство при температуре от 0 до 40°C и относительной влажности 30 - 90%. Длительное хранение допускается только в заводской упаковке, в темном, сухом, чистом, хорошо вентилируемом закрытом помещении, изолированном от мест хранения кислот и щелочей. Допустимая относительная влажность окружающей среды 30 - 90%.

УСЛОВИЯ ГАРАНТИИ

Компания «HIPER Technology Ltd,» являющаяся изготовителем товаров (изделий) HIPER (далее по тексту – Изготовитель), выражает вам огромную признательность за ваш выбор. Мы сделали все возможное, чтобы данное изделие удовлетворяло вашим запросам, а качество соответствовало лучшим мировым образцам. «HIPER Technology Ltd» устанавливает срок службы устройств: 2 года. Срок службы отсчитывается от даты продажи изделия, если кратким руководством

пользователя изделия не установлено иное ограничение.

Все товары предназначены «HIPER Technology Ltd,» для поставок в Российскую Федерацию и, соответственно, изготовлены с учетом условий эксплуатации в этой стране. Чтобы убедиться в этом, просим вас проверить наличие на изделии и упаковке официальных знаков соответствия.

Во избежание недоразумений убедительно просим вас внимательно изучить краткое руководство, условия гарантийных обязательств, проверить правильность заполнения гарантийного талона. Гарантийный талон действителен только при наличии правильно и четко указанных: модели, серийного номера изделия, даты продажи, четких печатей фирмы-продавца, подписи покупателя. Модель и серийный номер изделия должны соответствовать указанным в гарантийном талоне. При нарушении этих условий, а также в случае, когда данные, указанные в гарантийном талоне изменены, стерты или переписаны, гарантийный талон признается недействительным.

В этом случае рекомендуем вам обратиться к продавцу для получения нового гарантийного талона, соответствующего вышеуказанным условиям, либо предоставить товарный или кассовые чеки, либо иные документы, удостоверяющие факт и дату продажи изделия. В случае, если дату продажи установить невозможно, в соответствии с законодательством Российской Федерации о защите прав потребителей, гарантийный срок исчисляется с даты изготовления изделия.

Данным гарантийным талоном «HIPER Technology Ltd» подтверждает принятие на себя обязательств по удовлетворению требований потребителей,

установленных действующим законодательством о защите прав потребителей, в случае обнаружения недостатков изделия, возникших по вине Изготовителя. «HIPER Technology Ltd» оставляет за собой право отказать в удовлетворении требований потребителей по гарантийным обязательствам в случае несоблюдения изложенных ниже условий. Все условия гарантийных обязательств действуют в рамках законодательства о защите прав потребителей и регулируются законодательством стран импортеров. «HIPER Technology Ltd» устанавливает гарантийный срок 12 месяцев отсчитываемый от даты продажи

УСЛОВИЯ ГАРАНТИЙНЫХ ОБЯЗАТЕЛЬСТВ

1. Гарантийные обязательства Изготовителя распространяются только на модели изделий, предназначенные «HIPER Technology Ltd» для поставок и реализации на территории Российской Федерации, приобретенные в Российской Федерации, и прошедшие сертификацию на соответствие стандартам страны.

2. Под Гарантийными обязательствами понимается дополнительное обязательство Изготовителя по устранению недостатков (дефектов) изделия, возникших по вине Изготовителя, без взимания платы с покупателя (потребителя).

3. Замена изделия в период гарантийного срока (1 год), не ведет к установлению нового гарантийного срока.

4. Изготовитель не несет гарантийные обязательства в следующих случаях:

- а) Если изделие, предназначено для личных (бытовых, семейных) нужд, использовалось для осуществления предпринимательской деятельности, а также в иных целях, не соответствующих его прямому назначению;
- б) В случае нарушения правил и условий эксплуатации,

изделия, изложенных в кратком руководстве и другой документации, передаваемой потребителю;

в) Если изделие имеет следы попыток ремонта;

г) Если дефект вызван изменением конструкции или схемы изделия, подключением внешних устройств, не предусмотренных Изготовителем;

д) Если дефект вызван действием непреодолимых сил, несчастными случаями, умышленными или неосторожными действиями потребителя или третьих лиц;

е) Если обнаружены повреждения, вызванные механическими повреждениями, воздействием влаги, высокими или низкими температур, коррозией, окислением, попаданием внутрь изделия посторонних предметов, веществ, жидкостей, насекомых или животных.

5. «HIPER Technology Ltd» снимает с себя ответственность за возможный вред, прямо или косвенно нанесенный продукцией HIPER людям, домашним животным, имуществу в случае, если это произошло в результате несоблюдения правил и условий эксплуатации, установки изделия; умышленных или неосторожных действий покупателя (потребителя) или третьих лиц. Также «HIPER Technology Ltd» снимает с себя ответственность за возможный вред, прямо или косвенно нанесенный изделиями HIPER соответствующего назначения, в результате изменения и повреждения, утраты данных и информации.

ИМПОРТЕР: ООО «Мерлион», Российская Федерация, 143401, Московская область, город Красногорск, бульвар Строителей, дом 4, корпус 1, этаж 8, кабинет 819 .Претензии принимает ИМПОРТЕР. Торговая марка HIPER. Артикул HBV-0031. Игрушка

конструктор HIPER STEM 3in1 ROBOT SAMURAI Изготовитель и его адрес: «ХАЙПЕР Технолоджи Лимитед» 3905 Ту Эксчендж скуэр, 8 Конноут плэйс, Гонконг, Китай. Филиал изготовителя: «ШЭНЬЧЖЭНЬ ХАЙПЕР ТЕХНОЛОДЖИ ЛИМИТЕД», адрес (юридический адрес): Эт. 3, зд. 1, шоссе Хуан У 11, промпарк Ин Тао Чжи, р-н Лунган, г. Шэньчжэнь, пров. Гуандун, 518100, Китай. Соответствует требованиям TP TC 008/2011 «О безопасности игрушек». Дата изготовления: март 2022 года. Срок службы 2 года с даты продажи. Страна производства: Китай.

Список сервис центров смотрите на сайте: <https://hiper-power.com/ru/sluzhba-remonta/>

Имейте при себе гарантийный талон при обращении в сервис центр.



Гарантийный талон

Партия PN HP22030000ME

Артикул __HBV-0031__

Дата и место приобретения

ВНИМАНИЕ!
Гарантийный талон недействителен без печати продавца.

Штамп магазина/продавца

© 2022 HIPER Technology Ltd. Все права защищены. Все торговые марки являются торговой собственностью их владельцев. Любые характеристики могут быть изменены без предварительного уведомления.



ТИП В



ТИП С



ROBOT
SAMURAI

ТИП А

1



③ 1:1



⑤ 1:1

① = 1



2 = ②

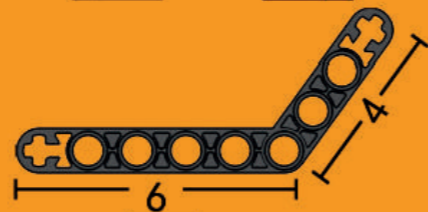

6X4

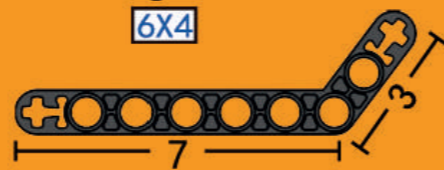

7X3



2 = ②



3 = ③

A



X2

⑥ X1

⑤ X1

2

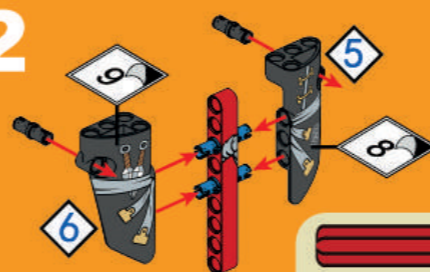

②

④

⑨ 1:1

X2

X1

⑨

1

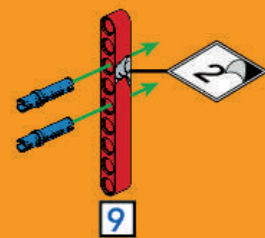

② X1

X2

④ X1

X1

3

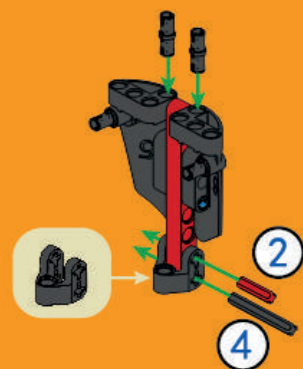

2

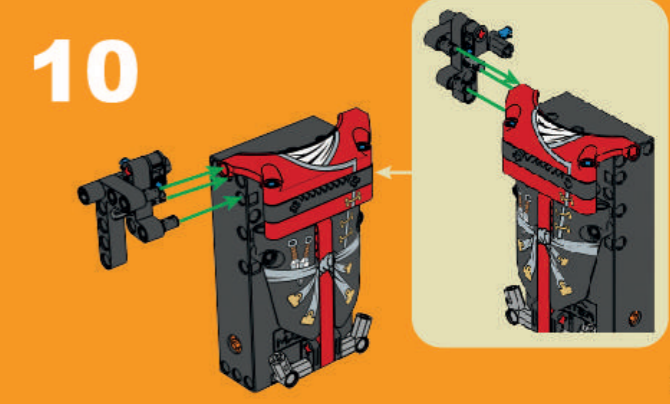
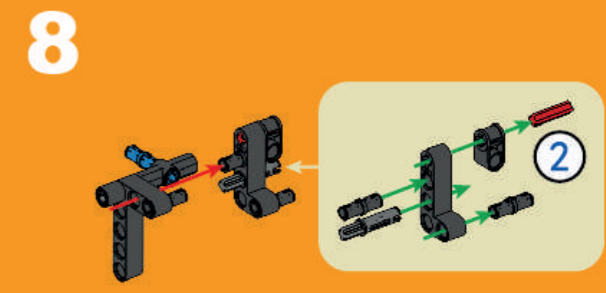
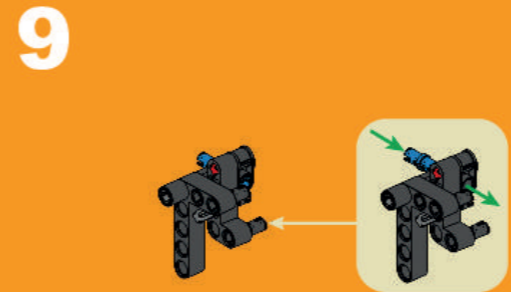
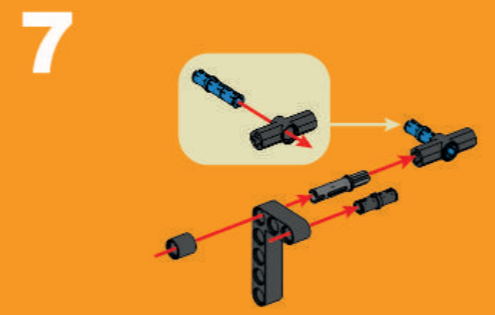
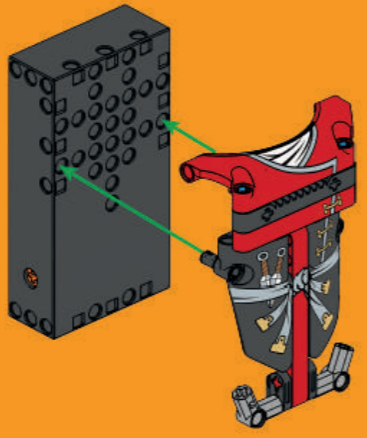
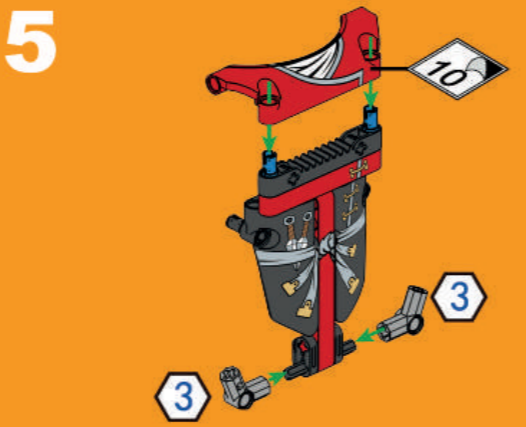
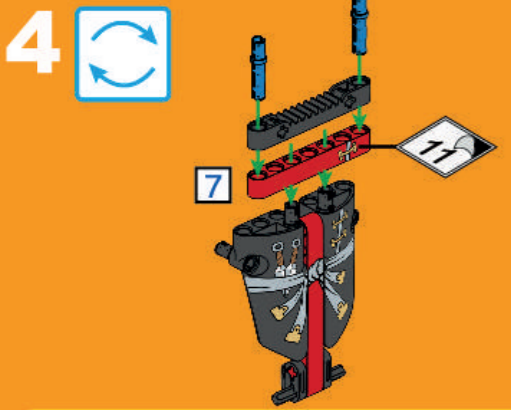

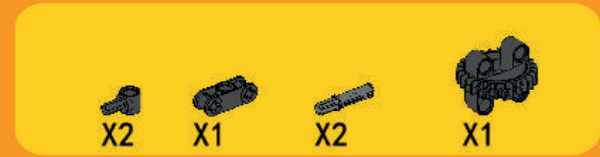

11

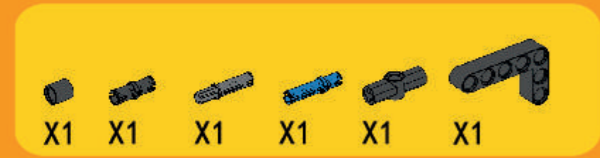
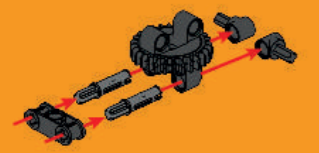

13

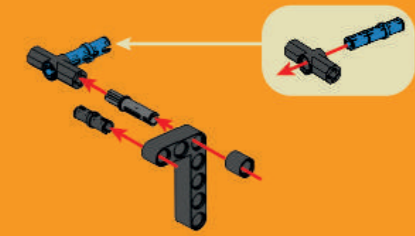

12

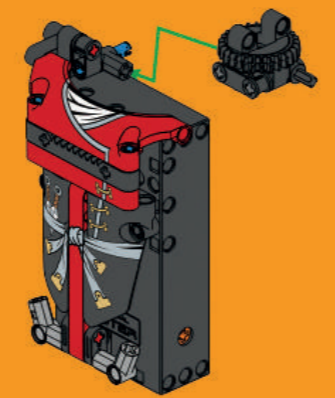

14



15

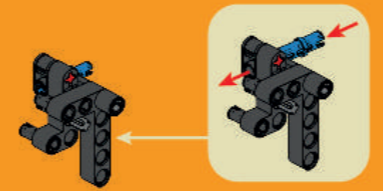

17

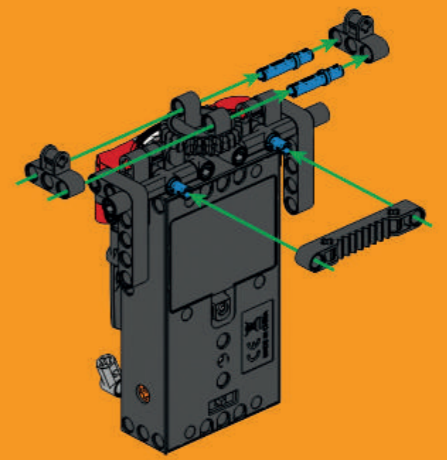

16

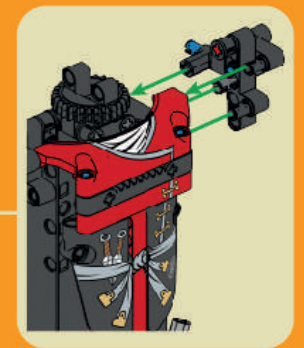
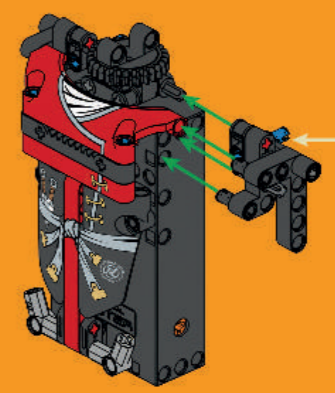

18

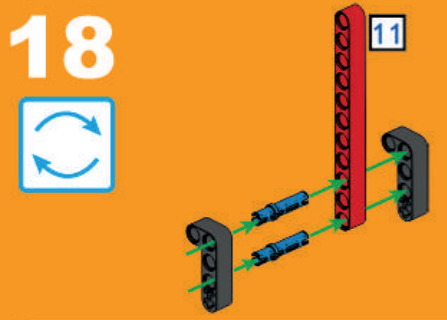
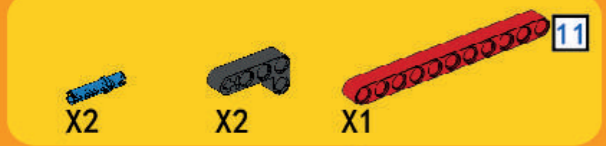

20

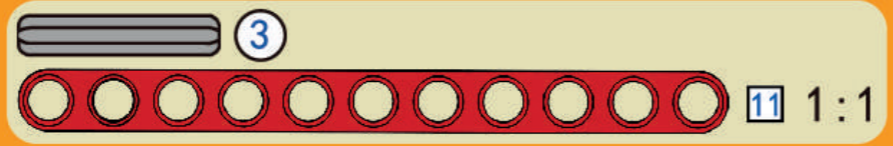
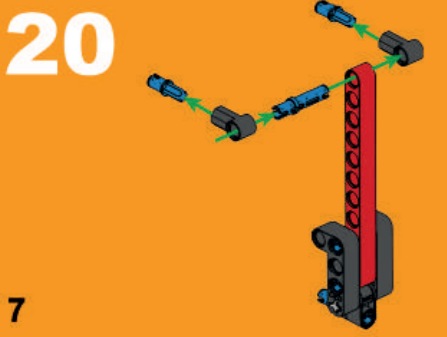

19

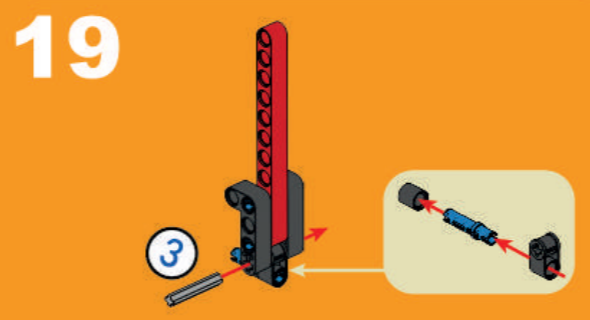

21

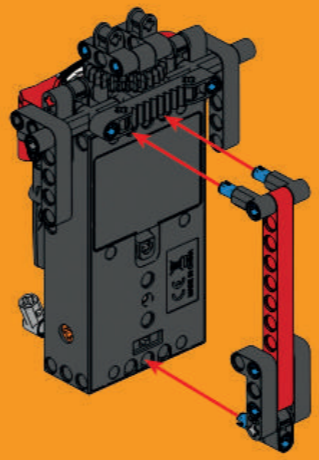

22

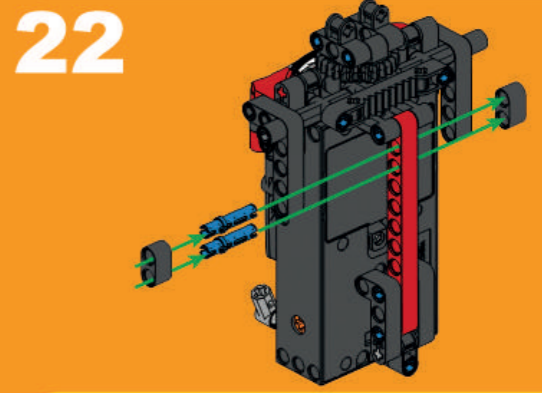

23

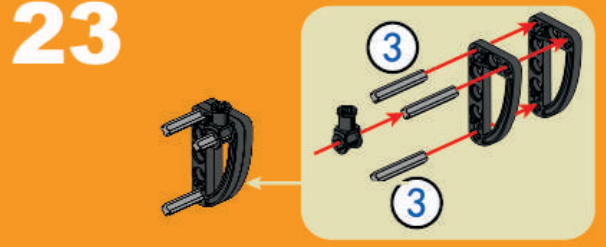

24



X2

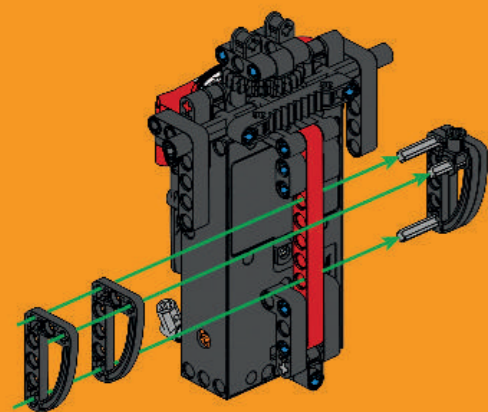

9

25



X4

X1

X1

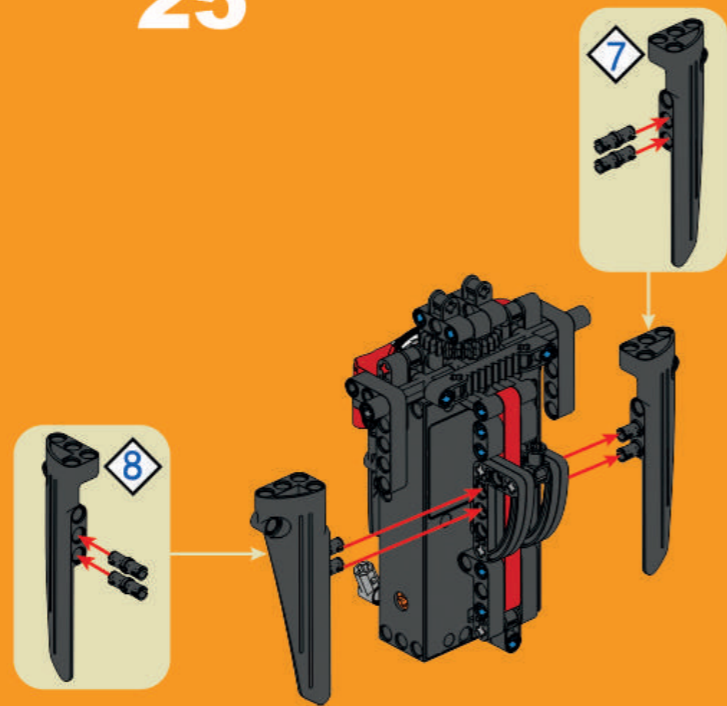

26



X1

X2

X1

X1



28



X2

X2

X2

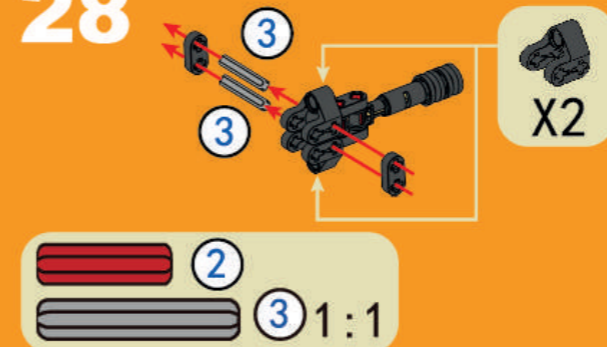

X2

X2

1:1

27



X2

X2

X1

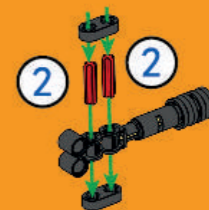

29



X1

X2

X1

X1

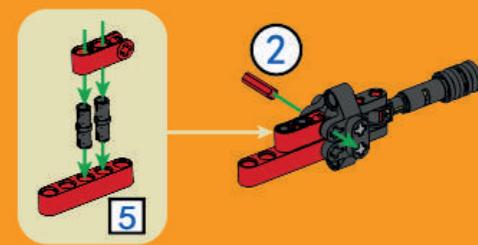

10

30

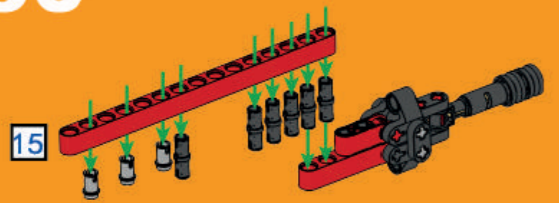

31

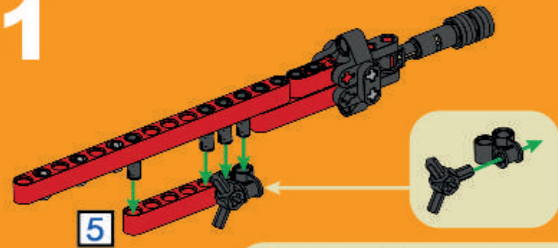

32

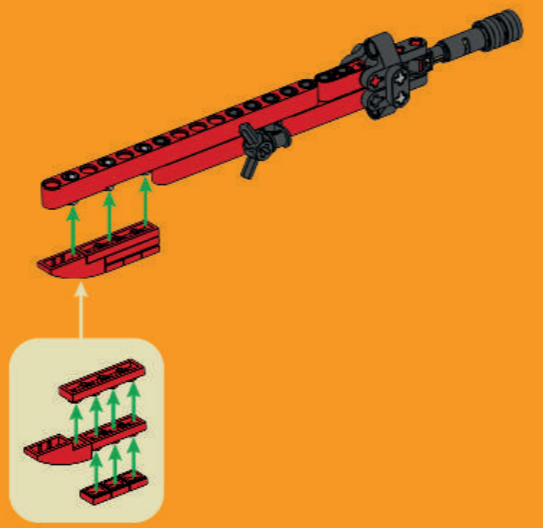
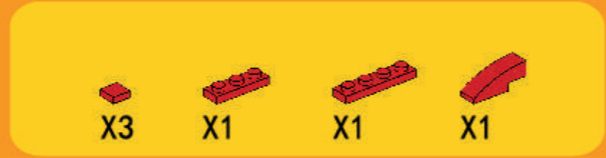

33

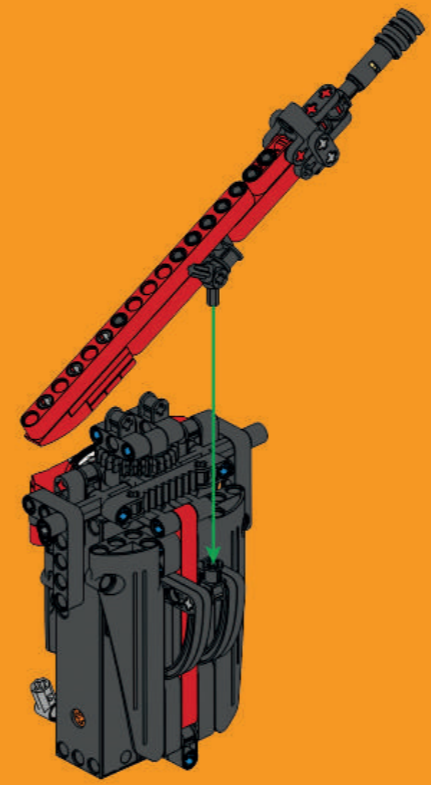

34

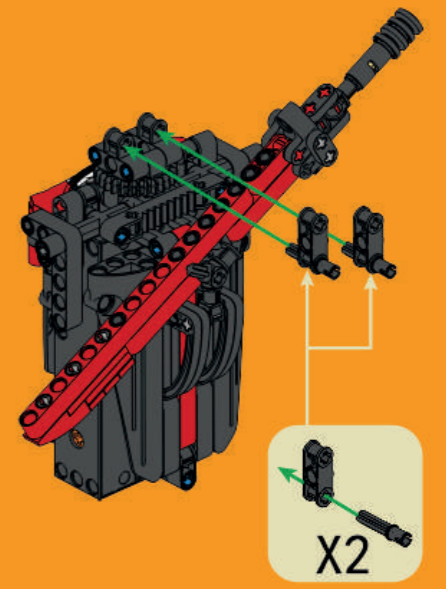



35

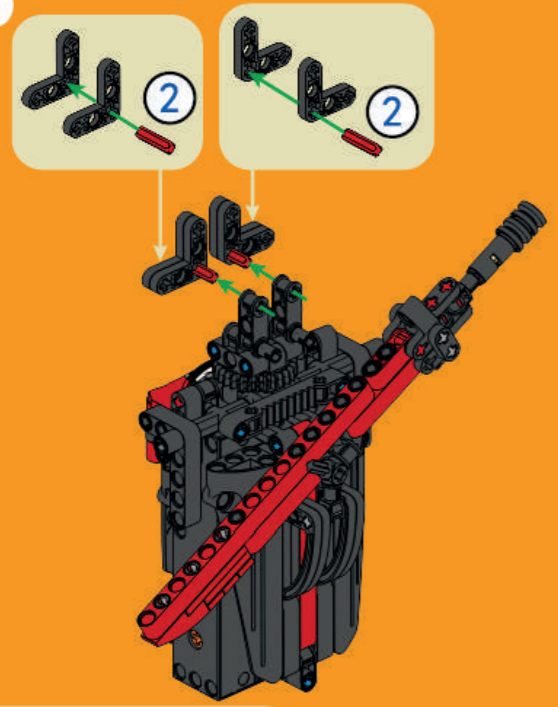

13



36

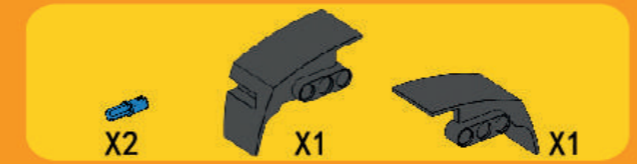
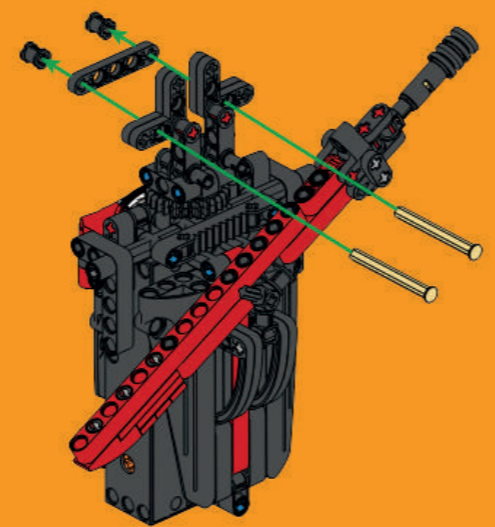

37

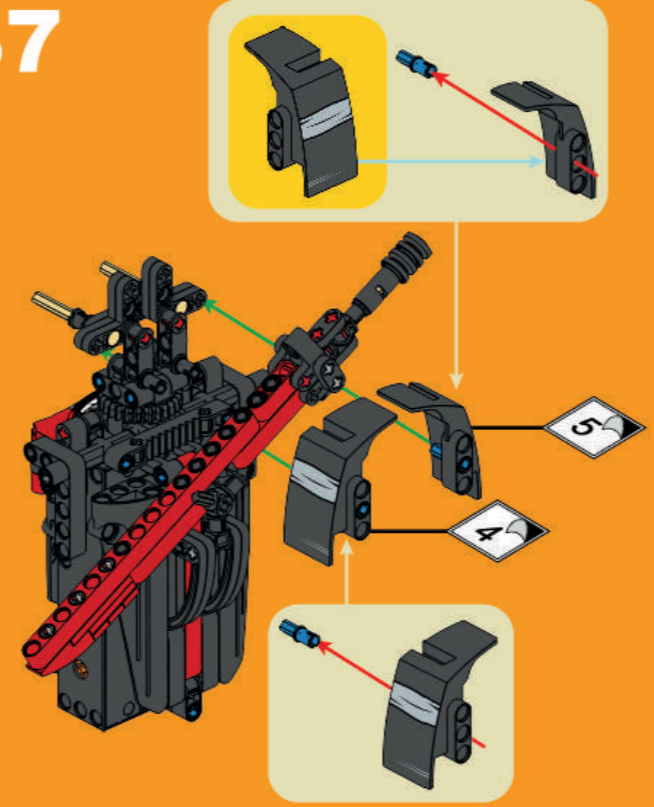

38

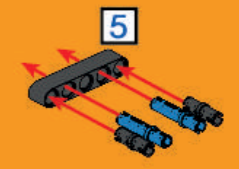

39

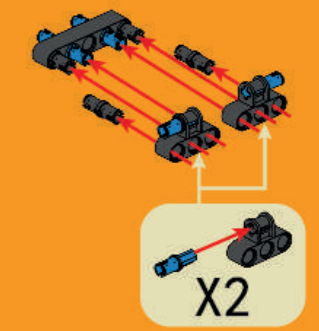

14

40

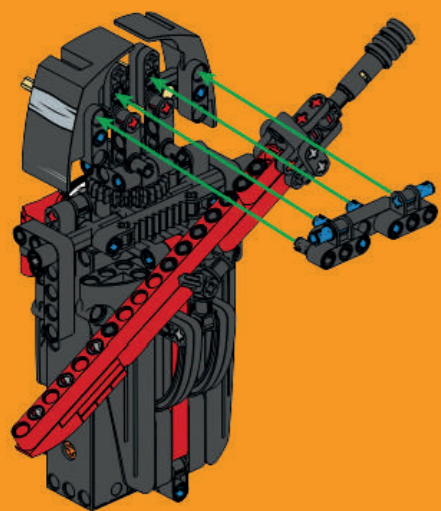

15  ② 1:1

41

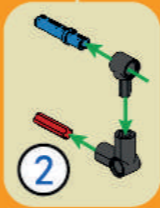
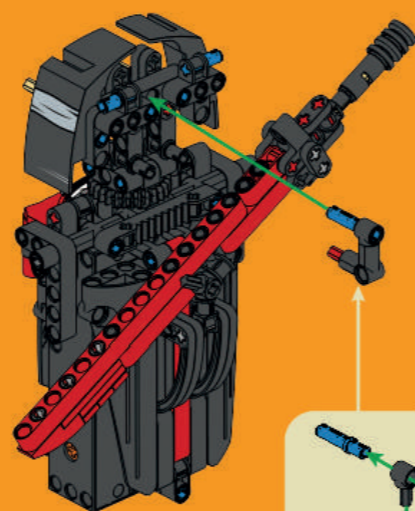

42

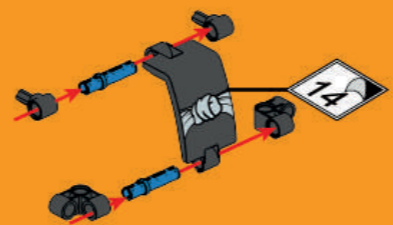

43

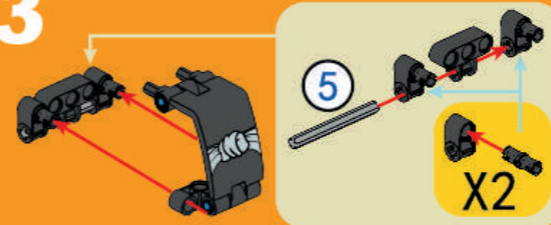

 ⑤ 1:1

44

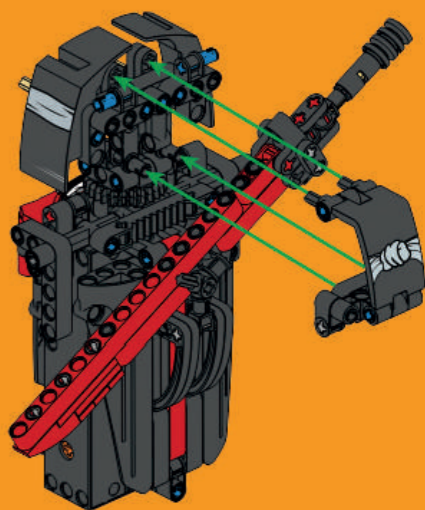

16

98

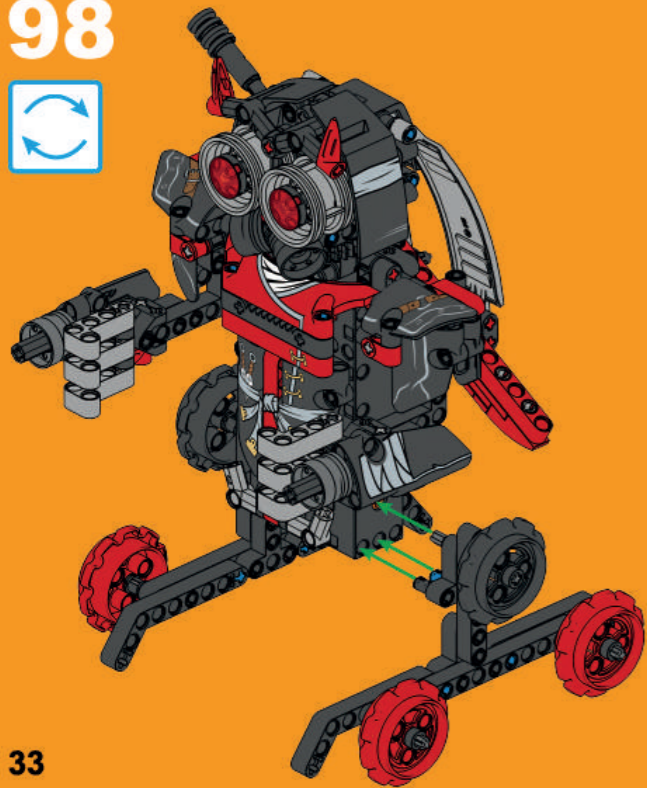

33

99



X29

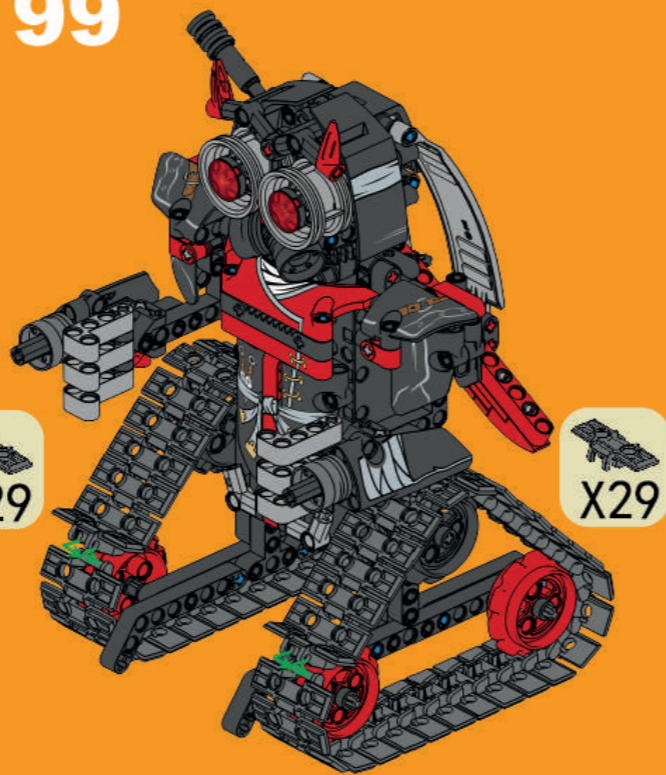

X29



X58

100

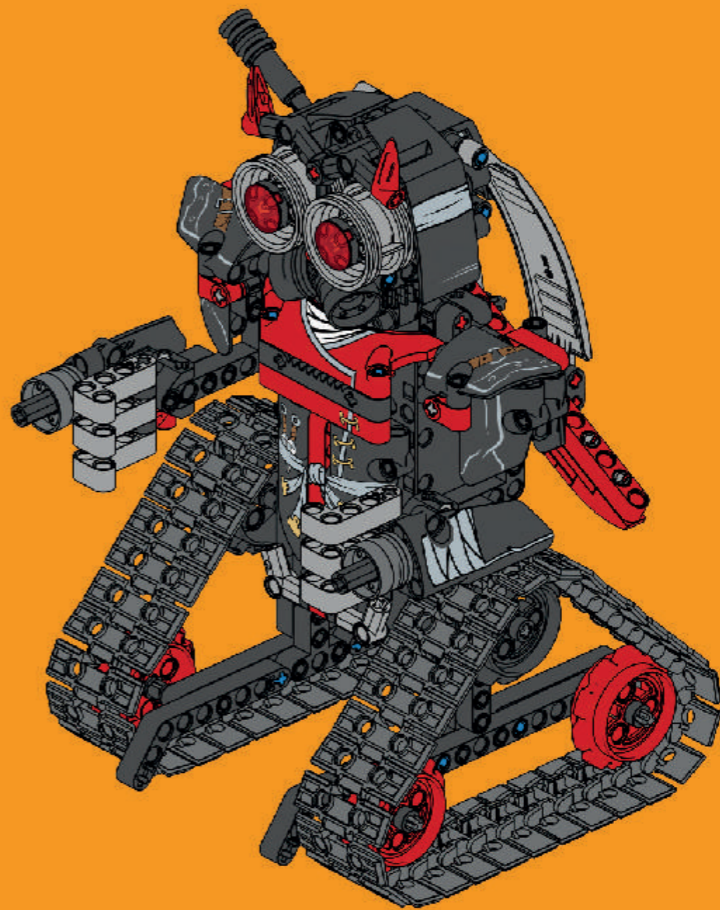

34

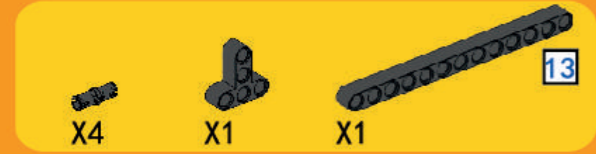

92

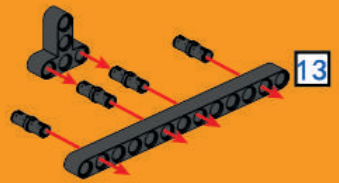

94

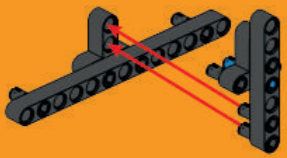

31



93

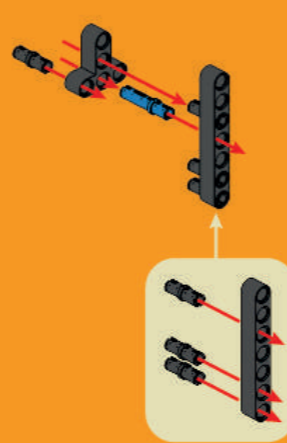

95

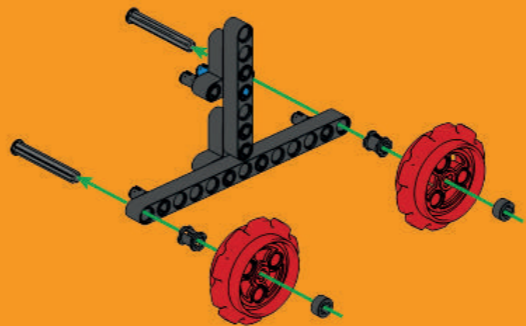

97

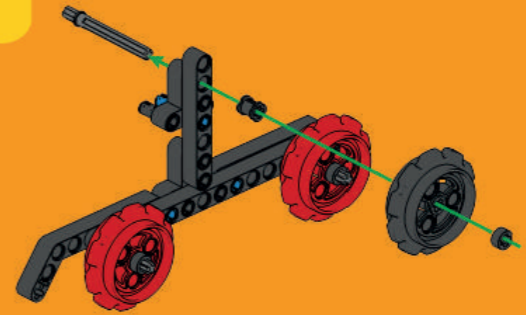

96

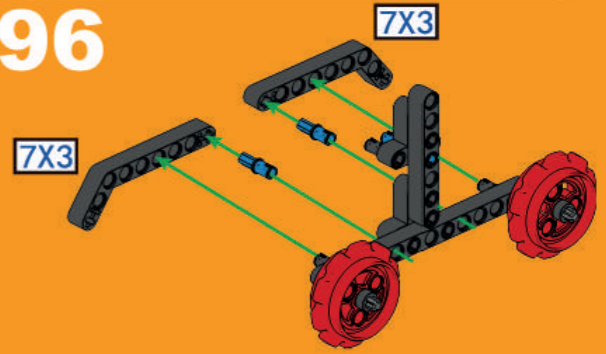

32

87

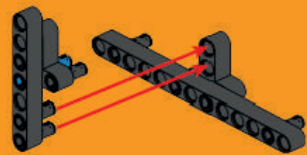

89

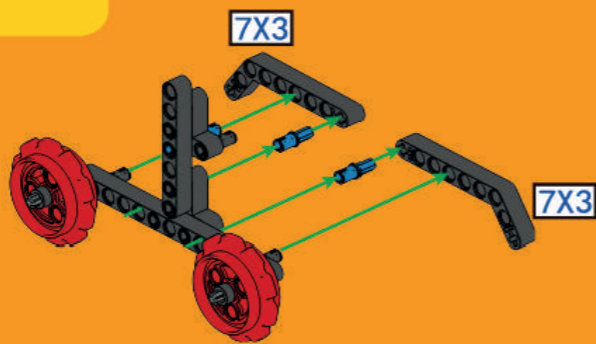

29

88

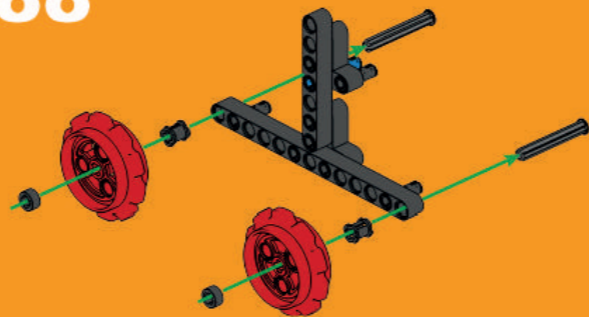

90

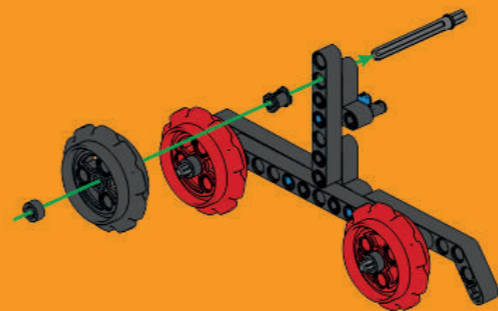

91

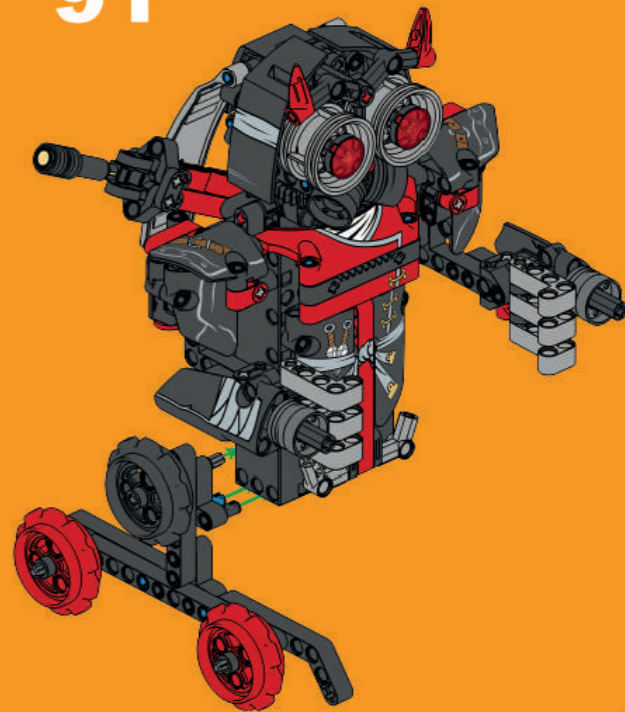

30



80

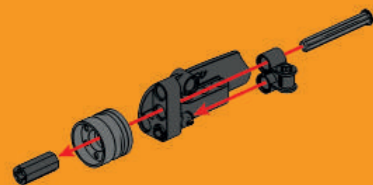

82

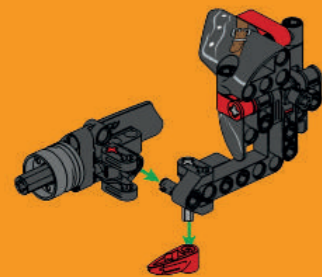

27



83

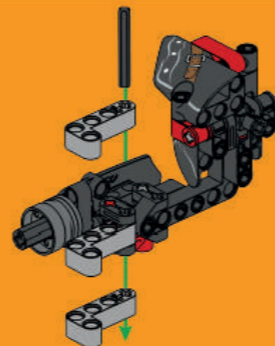

81

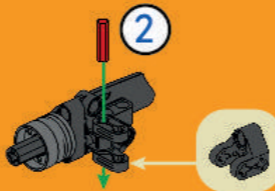

84

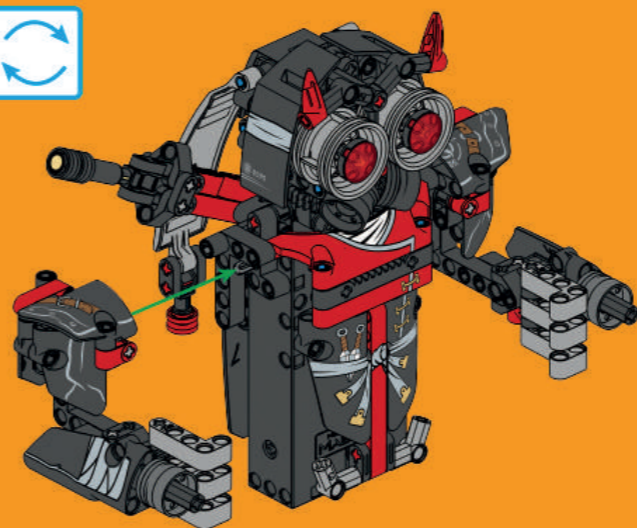

85

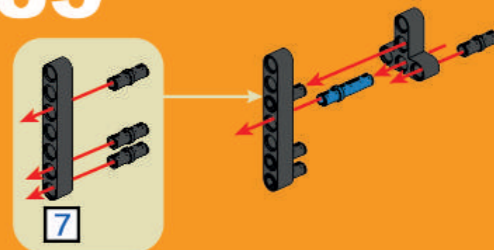

86

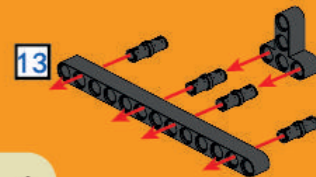

28



72

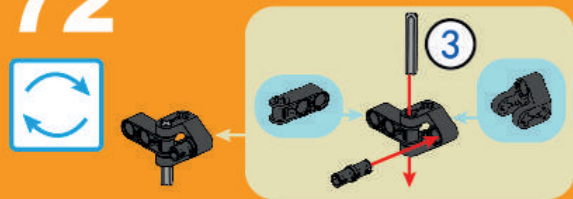

74

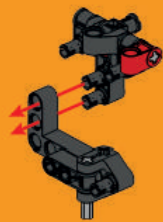

25



73

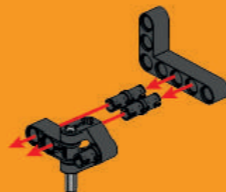

75

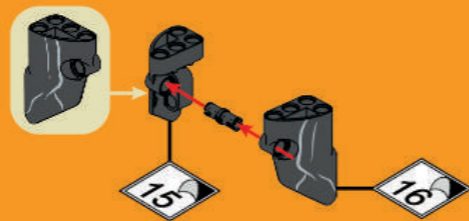

76

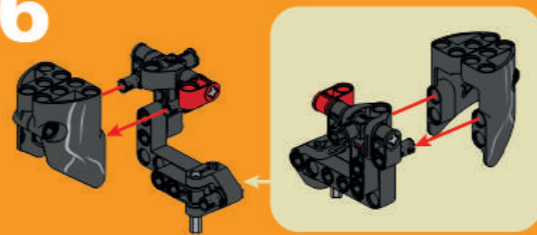

78



77

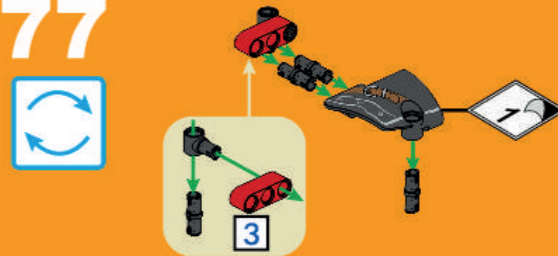

79

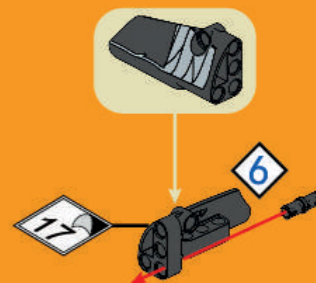

26



65

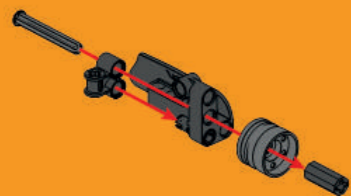

67

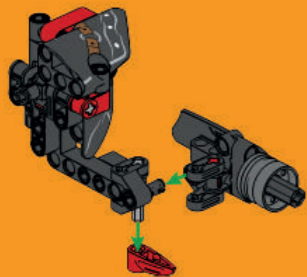

23



66

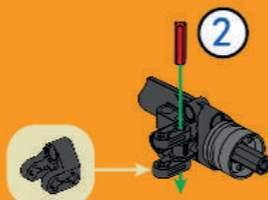

68

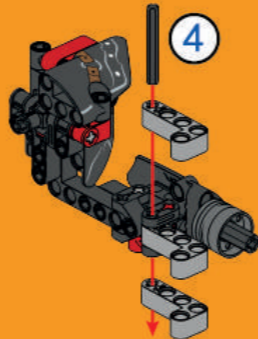

69

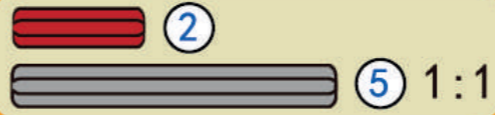
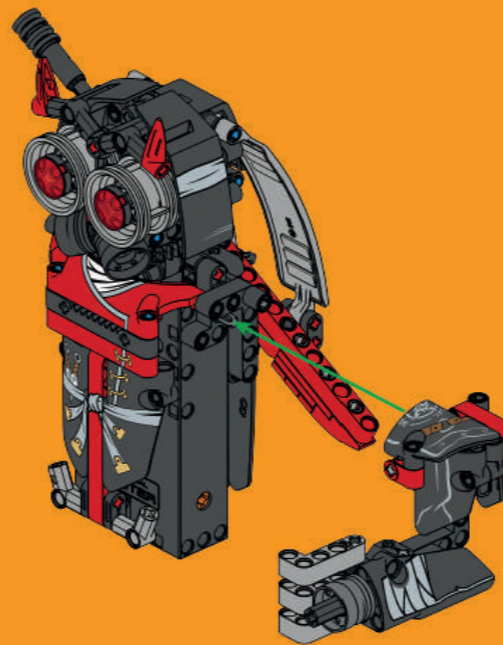

70

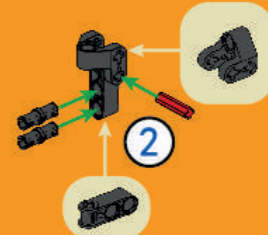

71

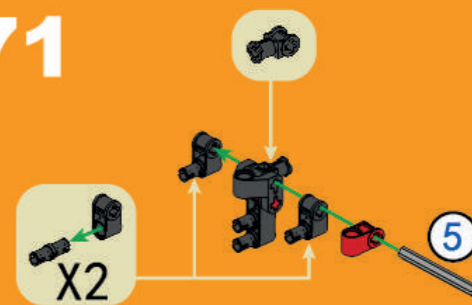

24



57

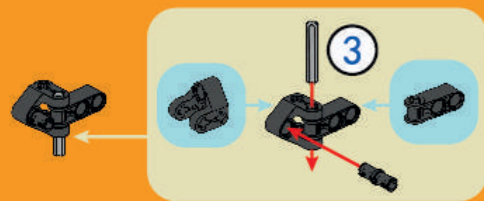

59



58



60

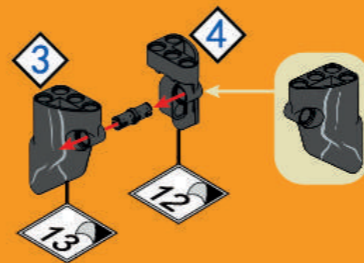

61

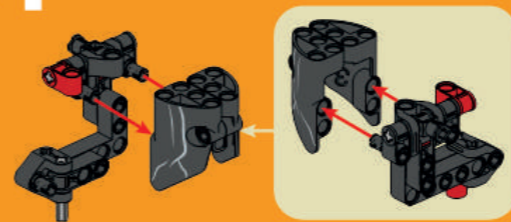

63



62

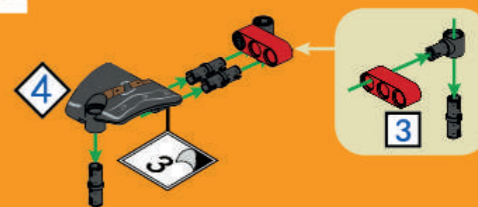

64

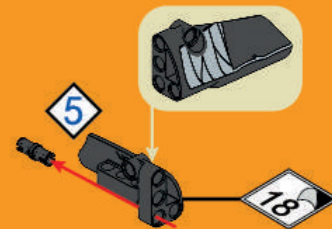



51



52

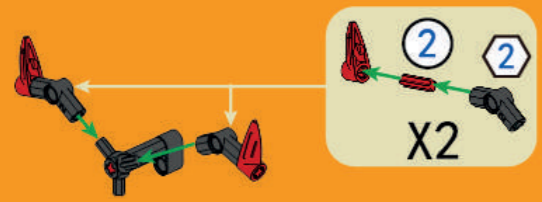

53

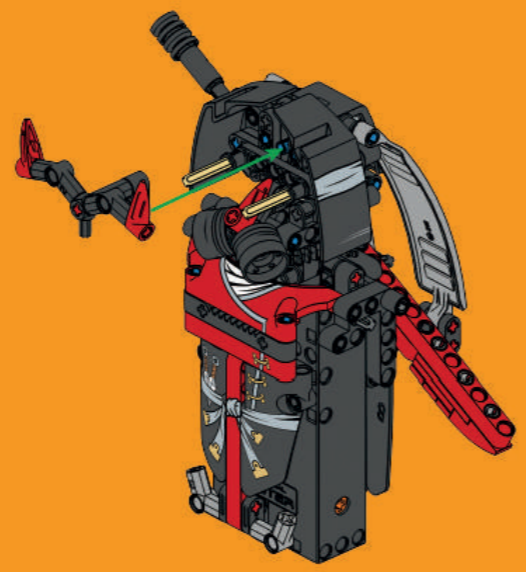

54

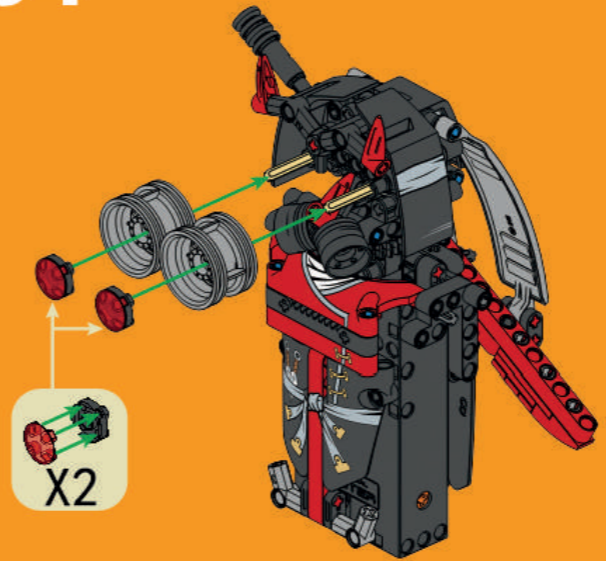
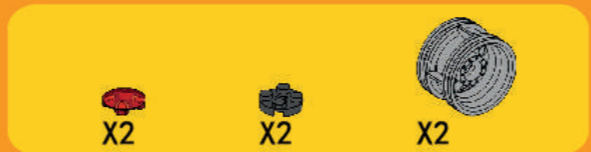

55

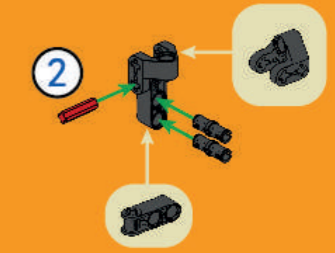

56

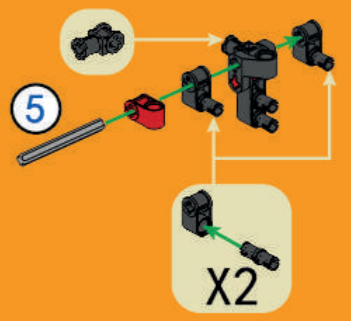



45

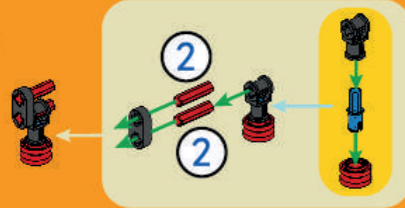

46

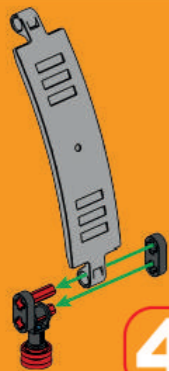

45-46 X2

17

47

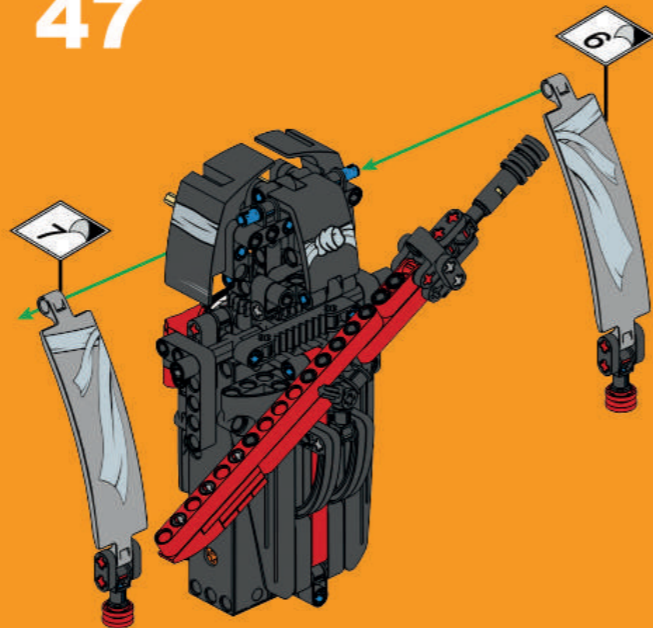

48



49

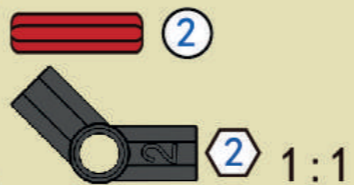

50

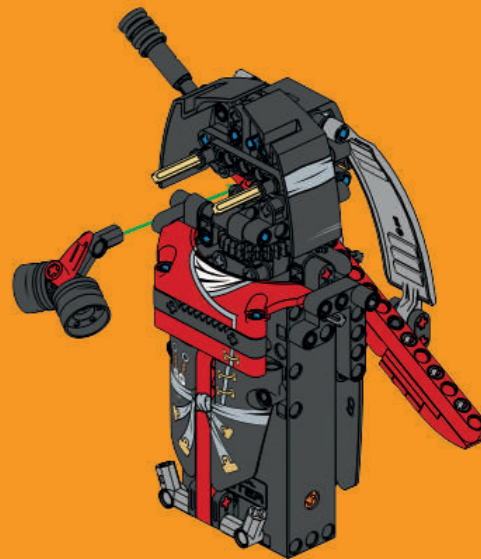

18

1

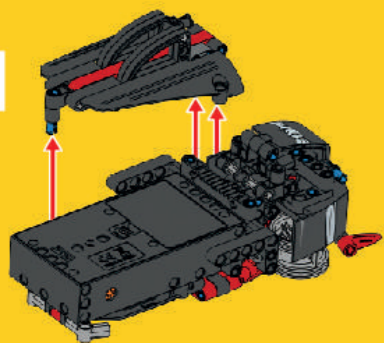

2

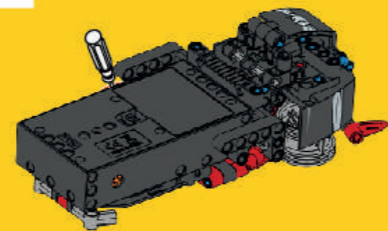

3

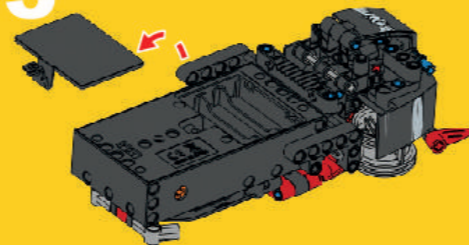

4

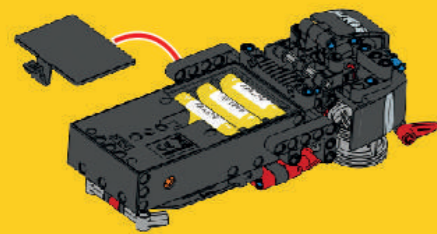

5

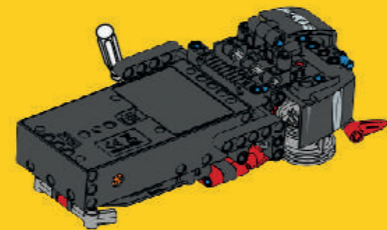

6

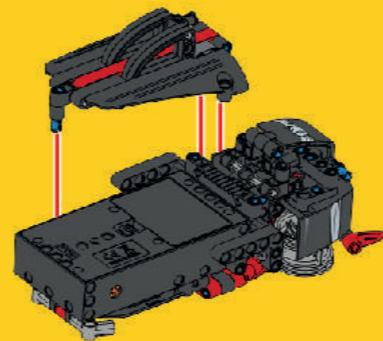

1

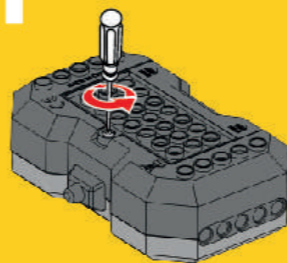

2

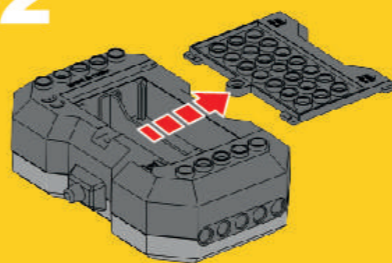

3

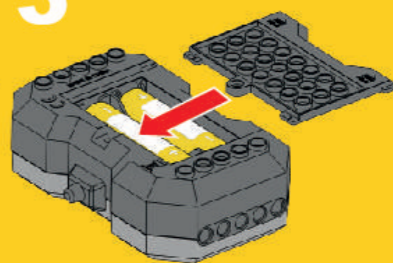

4

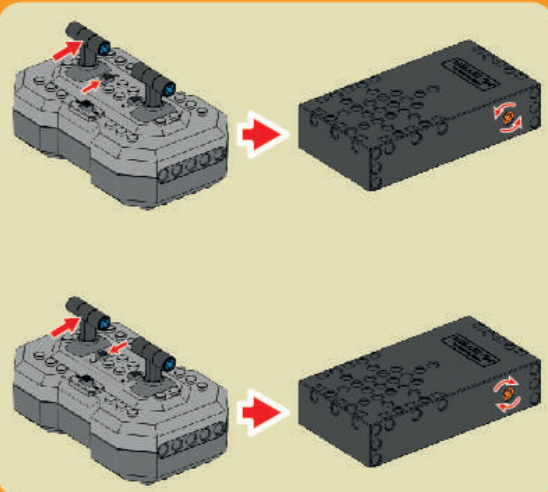
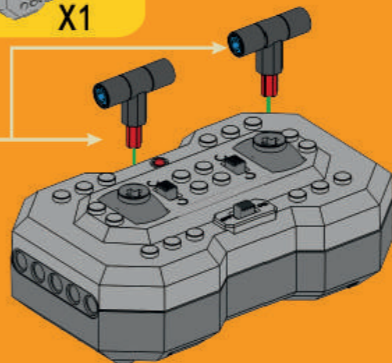
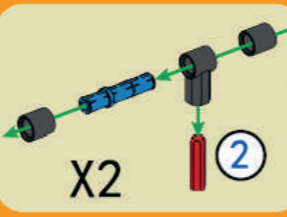
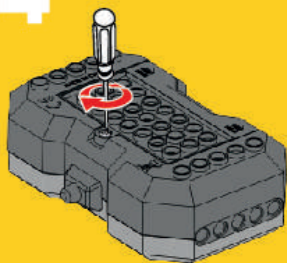

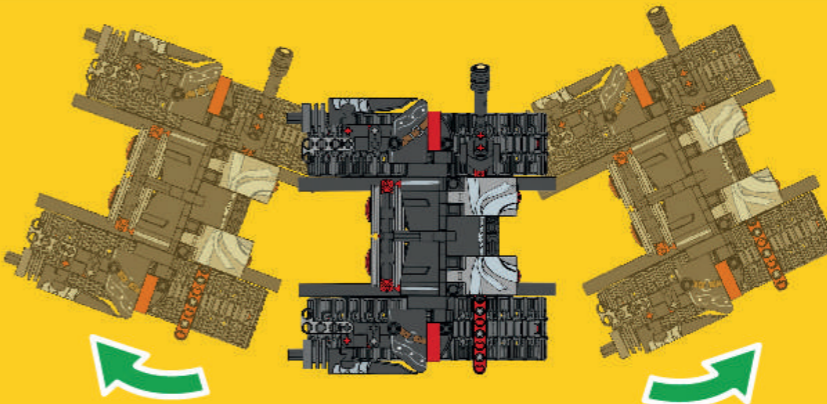
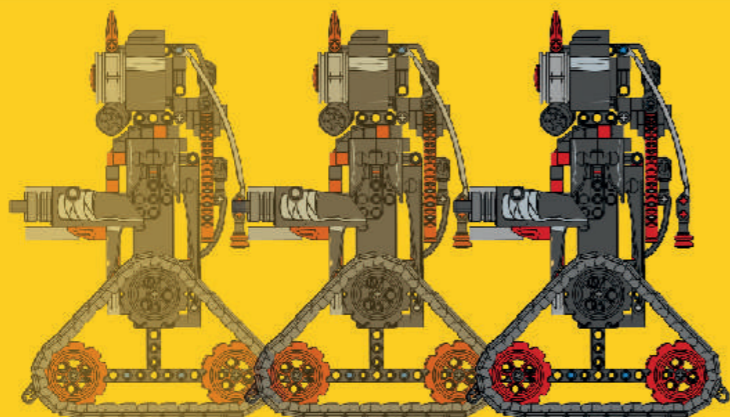
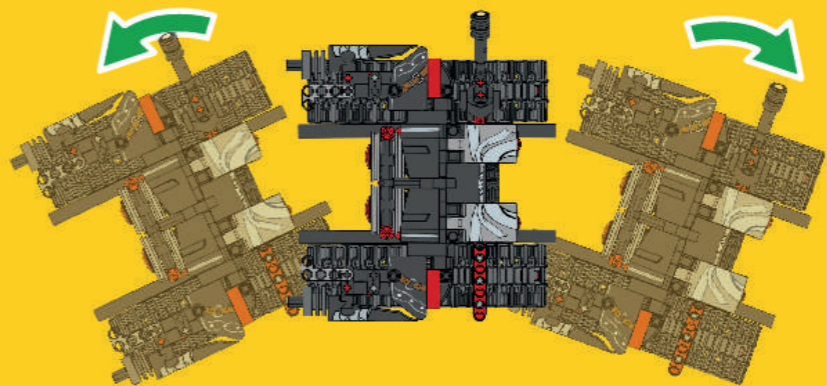
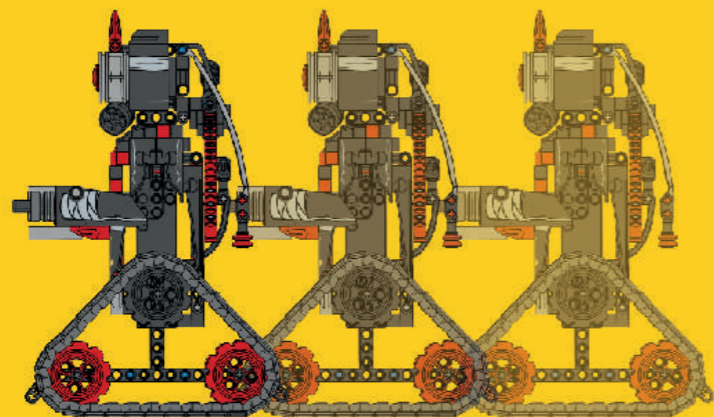

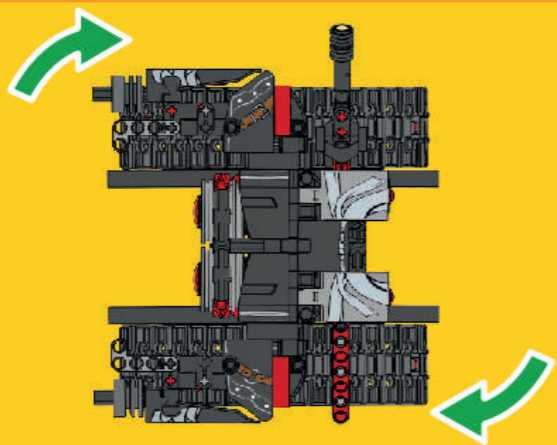
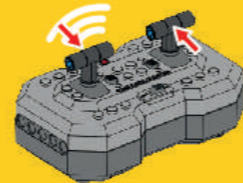
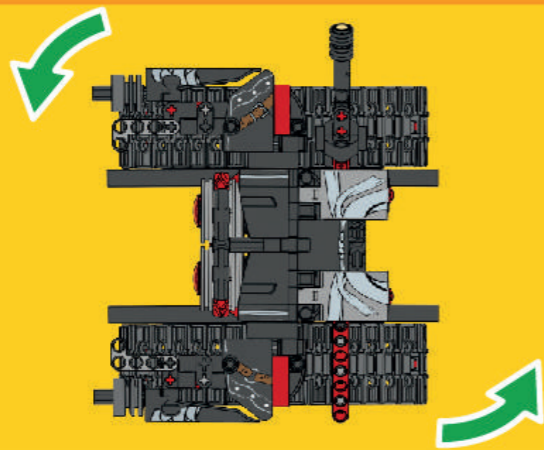

B

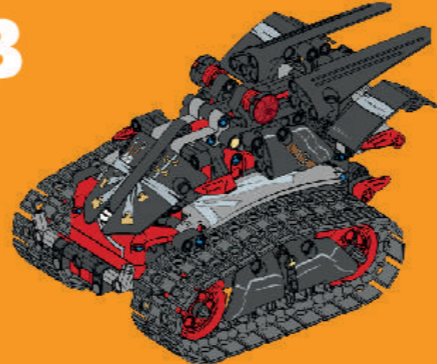

2

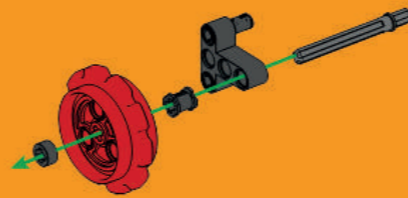

X2

X1

1

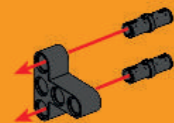

X1

3

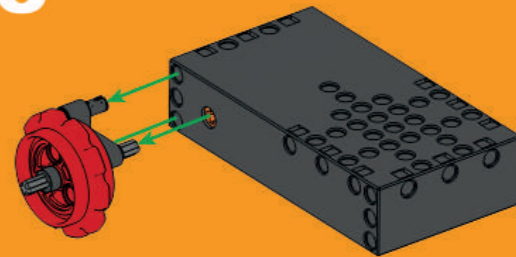



56

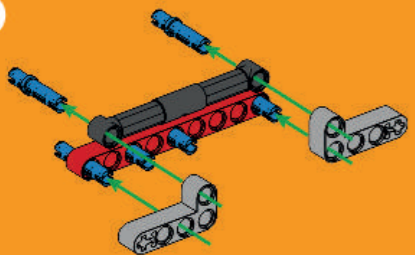

58

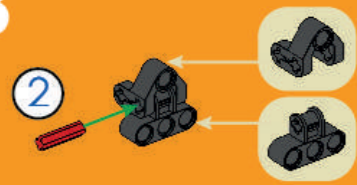

57

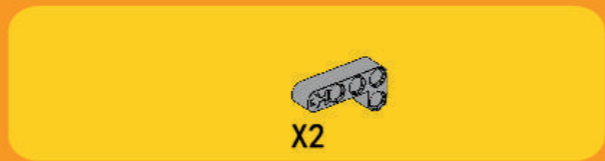

57

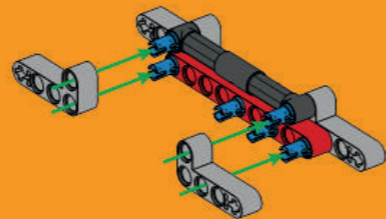

59

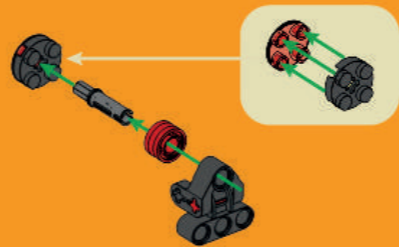

60

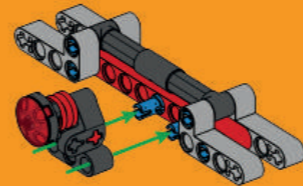

62

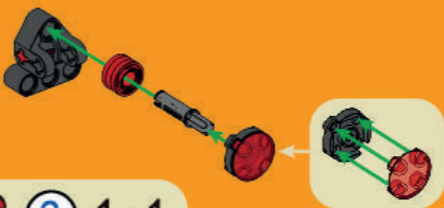

61

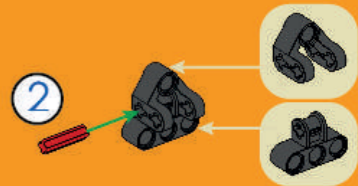

63

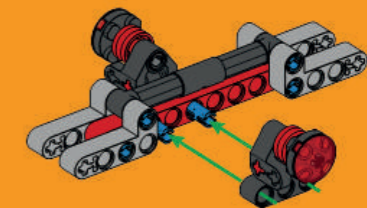

58

51

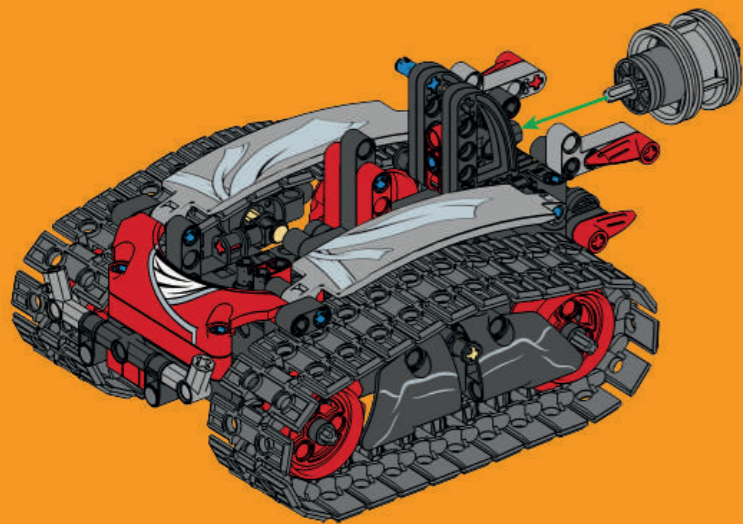

55



52

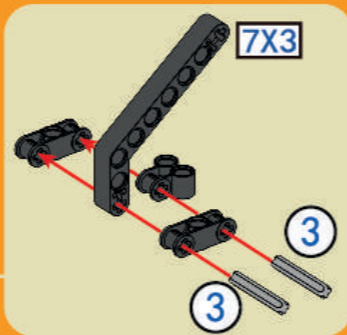
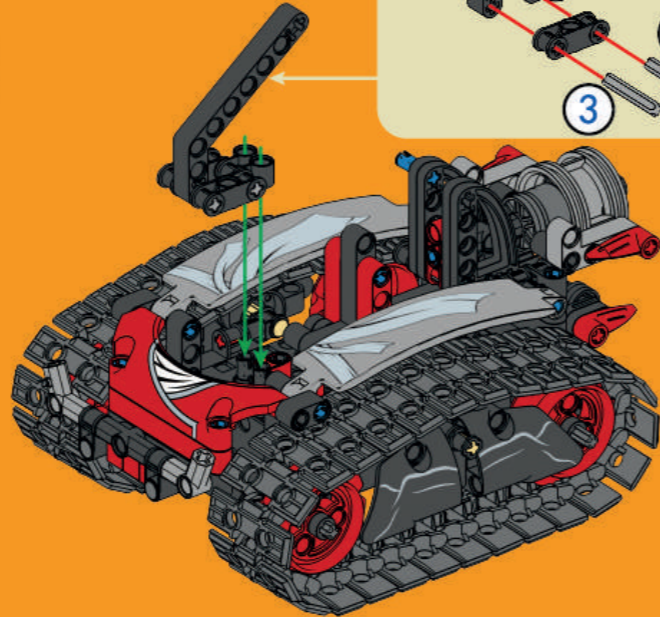

53

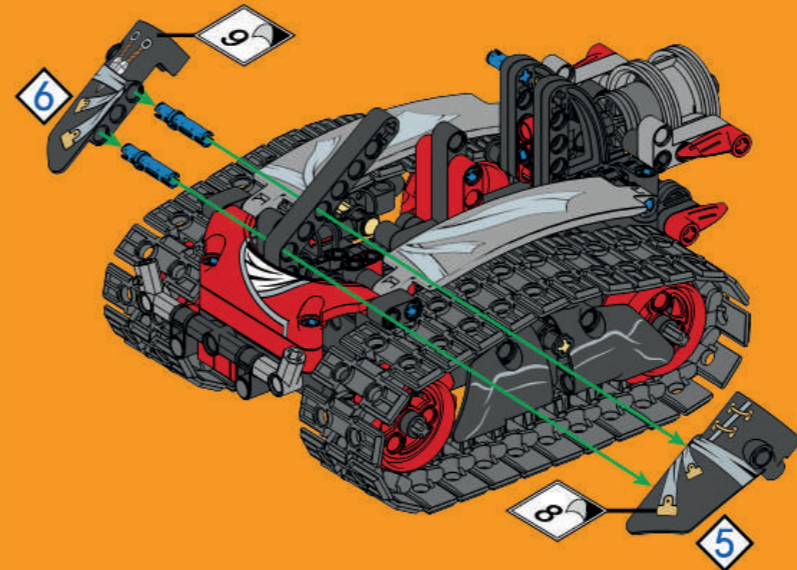

54

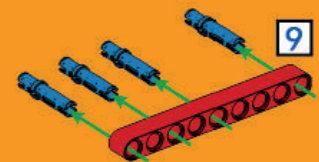

55

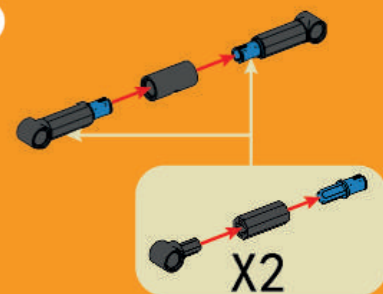

56



47

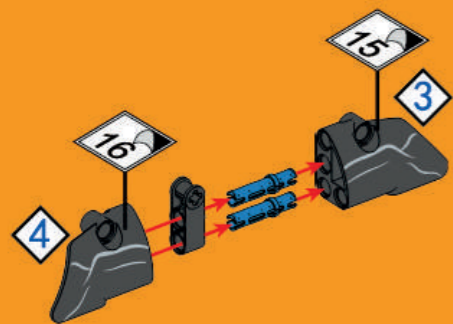

48

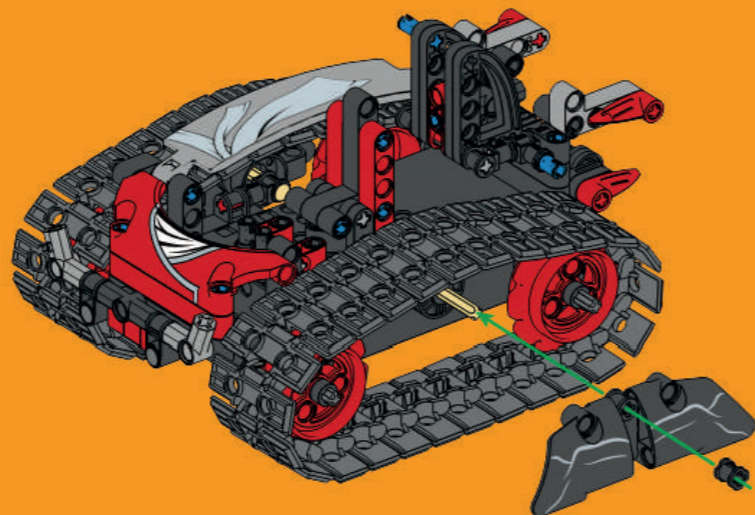

49

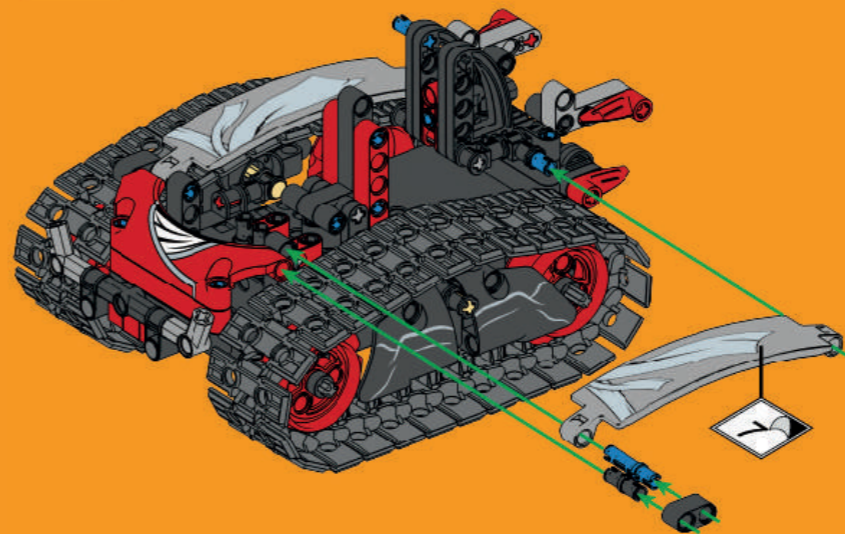

50

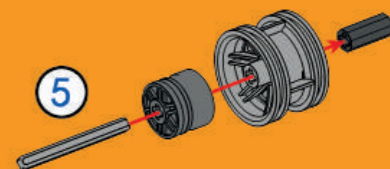

42

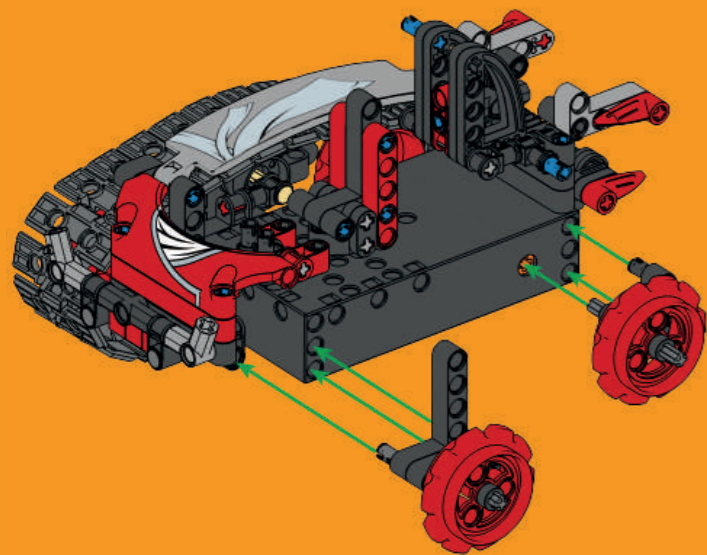

51



43

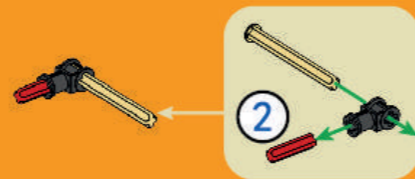

44

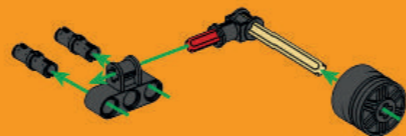

45

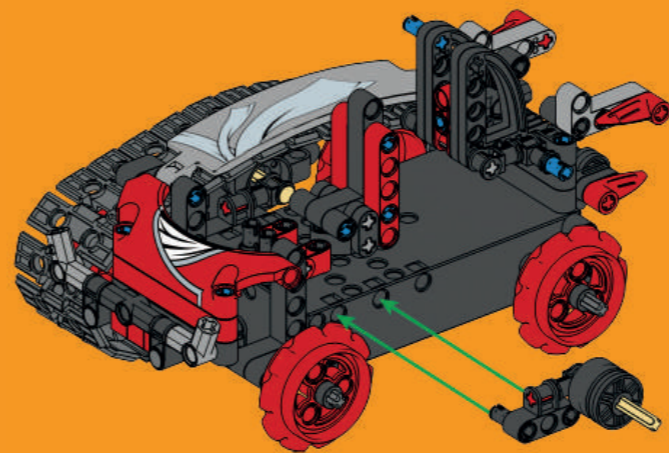

46



52



35

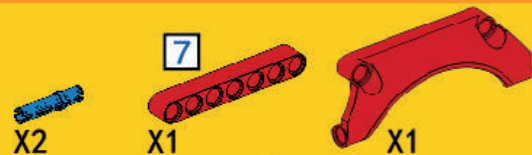
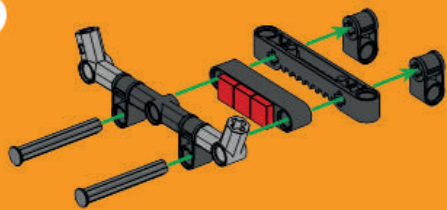

36

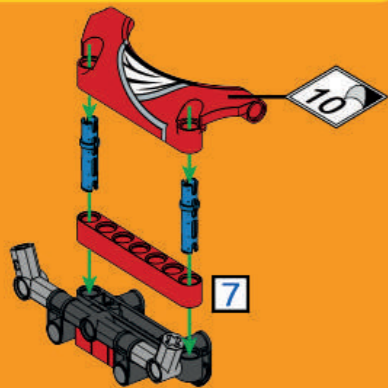

37

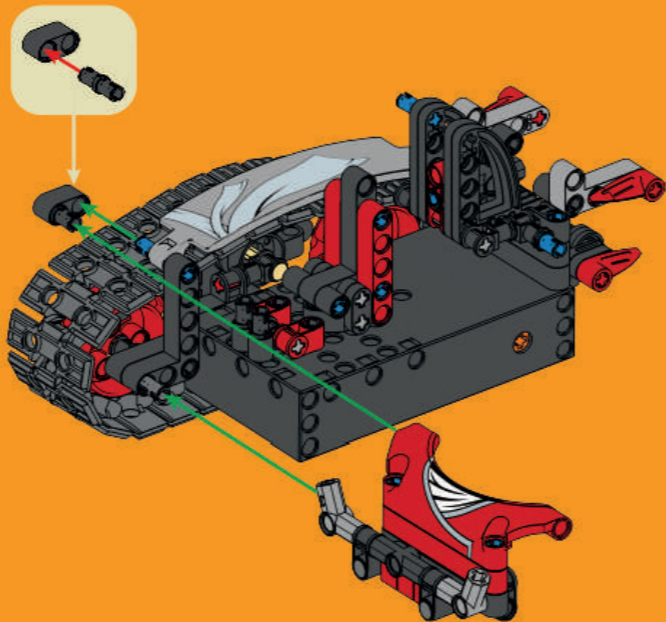

38



40

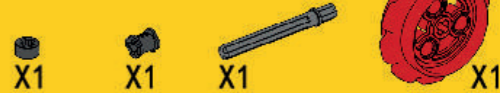
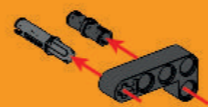

39

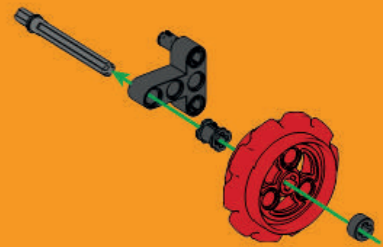

41

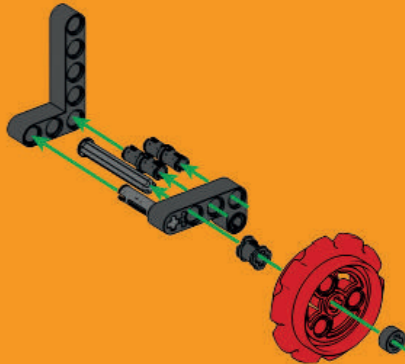



27

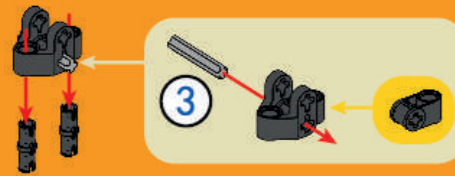

29

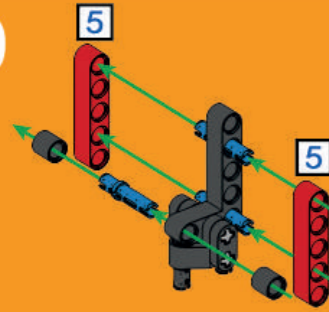

47

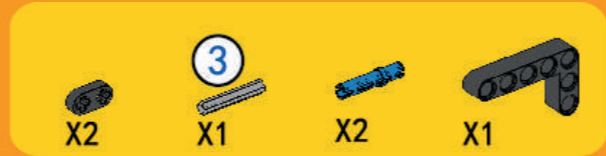

28

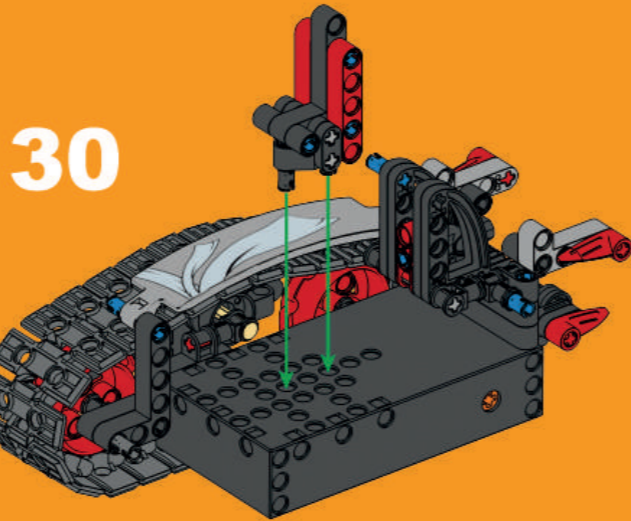
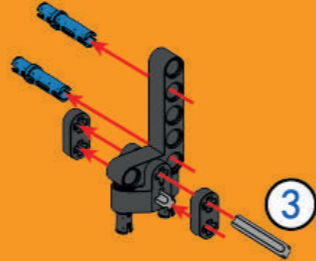

30

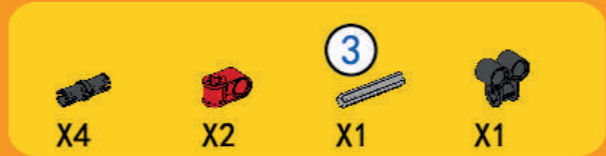

31

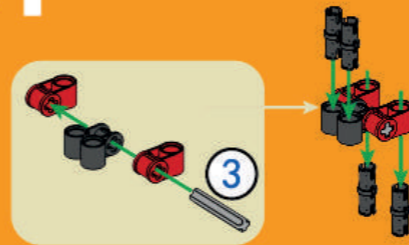

33

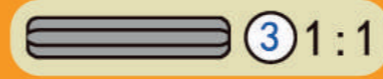
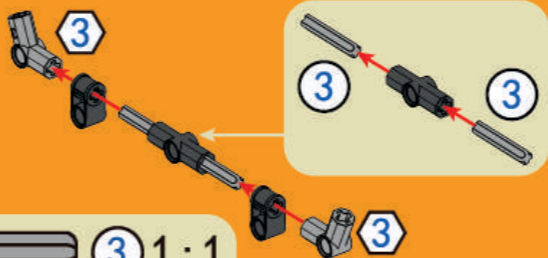

48

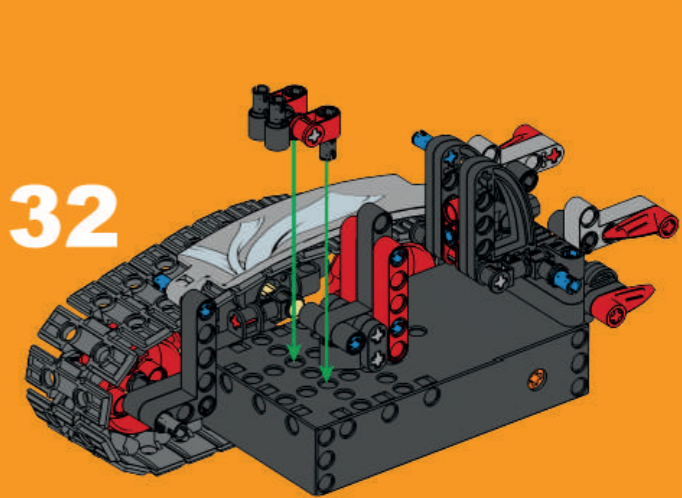

32



34

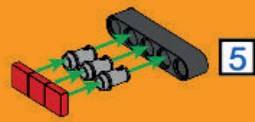

48

19

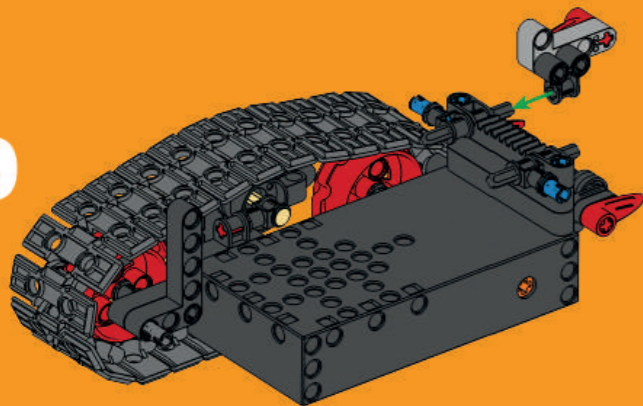

21

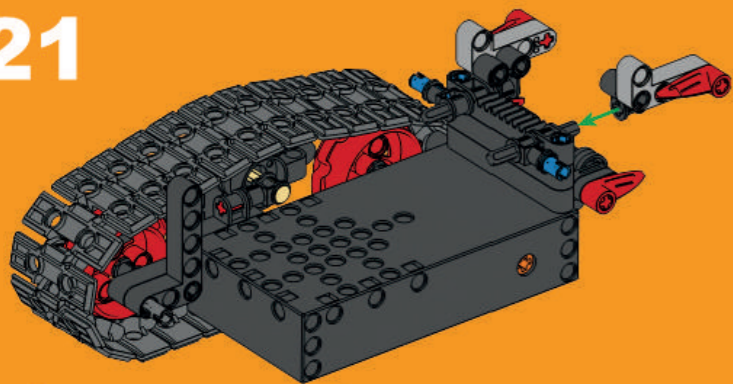

45



2

X1



X2



X1



X1



X1

20

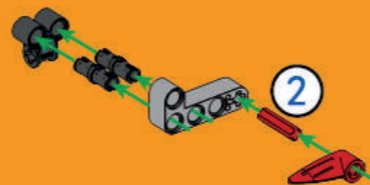

2



X1

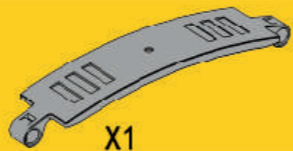

X1

22

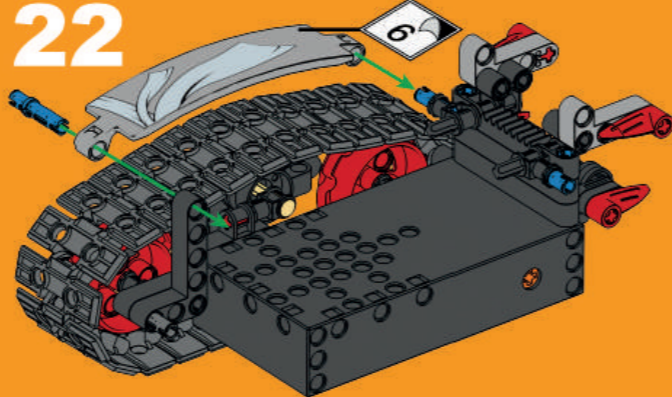

6

23

X1



X1



X1



X1

25

X1



X2



5

1:1

24

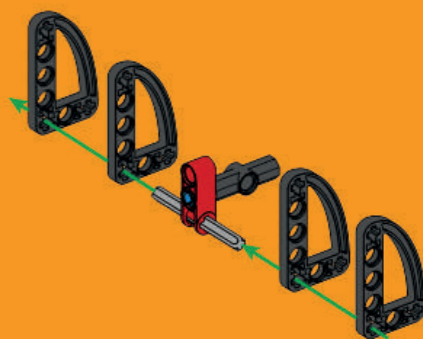

X4

26

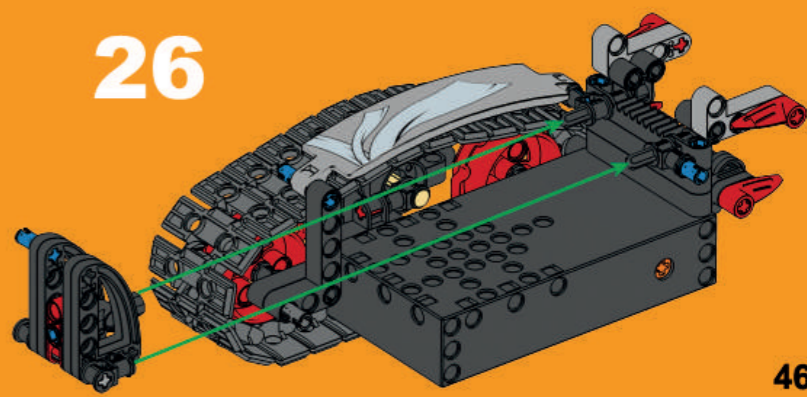

46

12

X26

X26

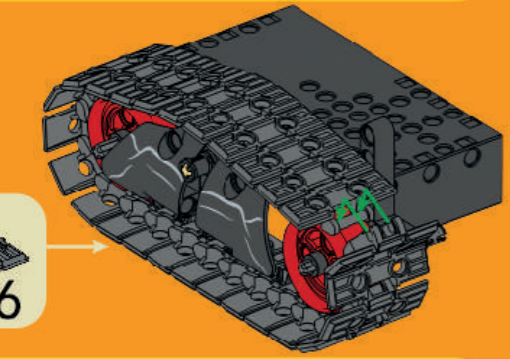

2

X2

X2

X2

X2

14

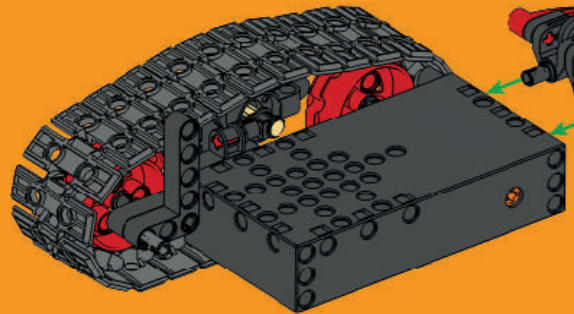

43

13

X2

X1

X3

7

X1

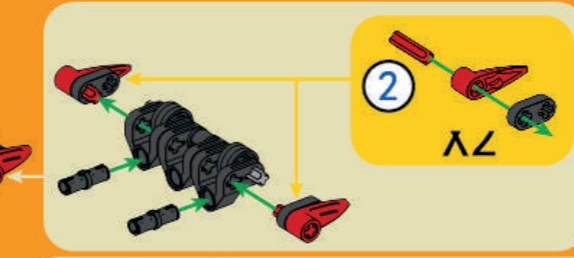
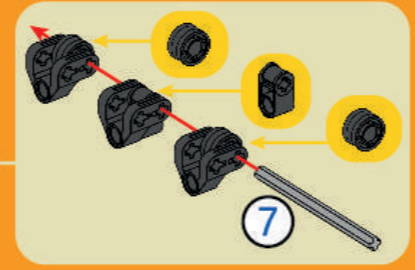

2

7

1:1



15

X2

X2

X1

X2

7

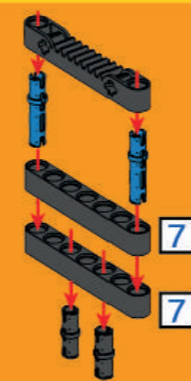

17

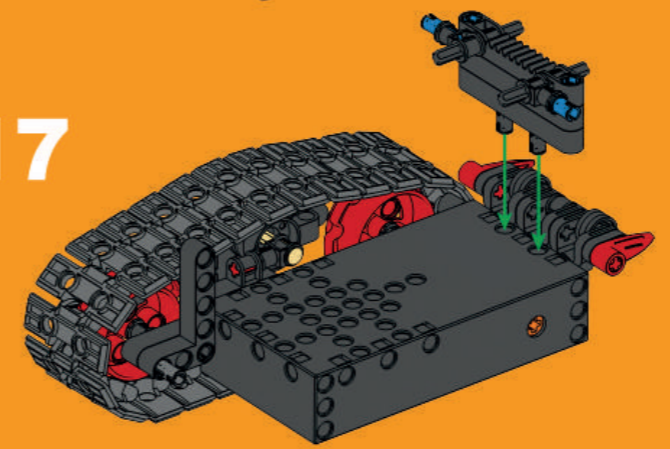

16

X2

X2

4

X2

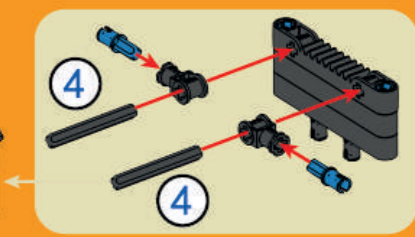
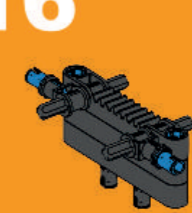

2

X1

X2

X1

X1

X1

18

2

2

4

1:1



44



4

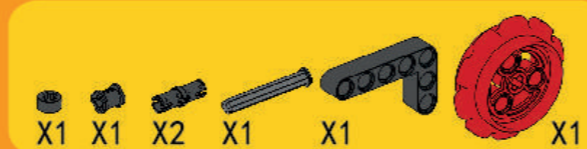
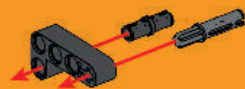

5

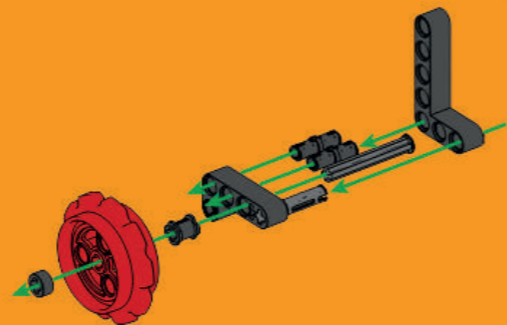

8

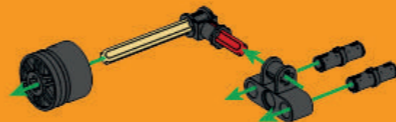

9

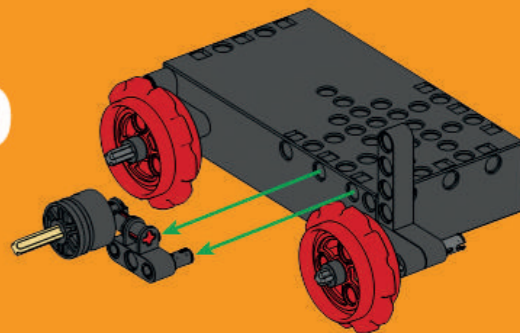

6

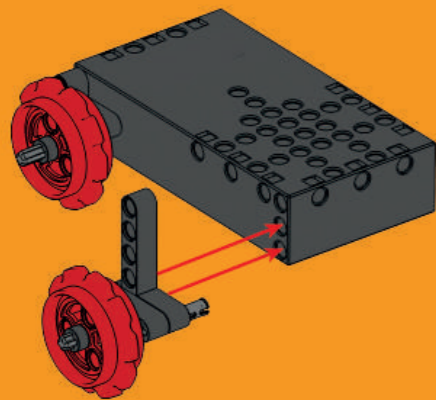

7



10

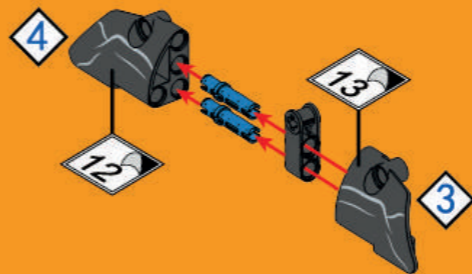

11

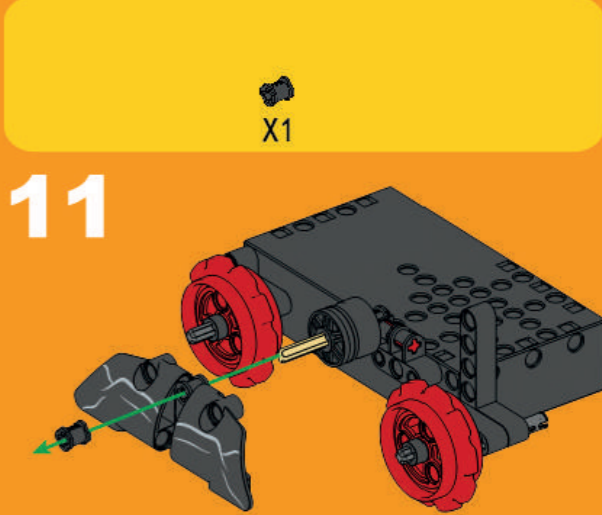



X1

64

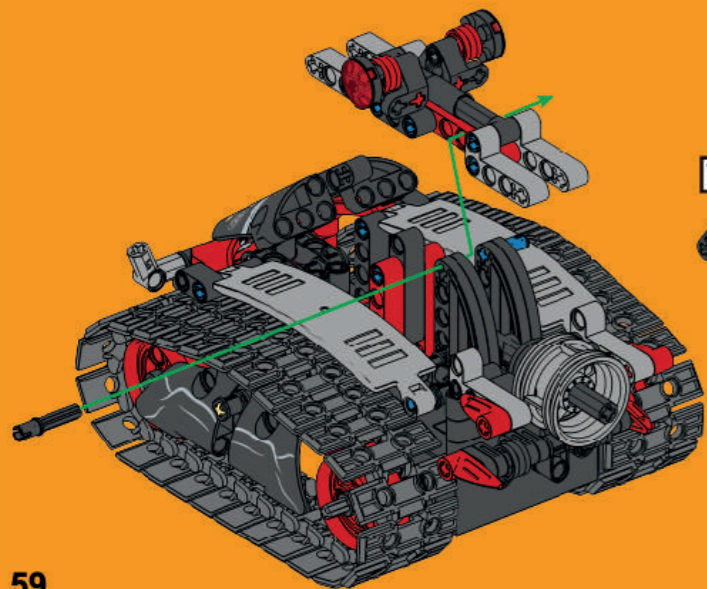

59



X1



7X3

X2

65



7X3

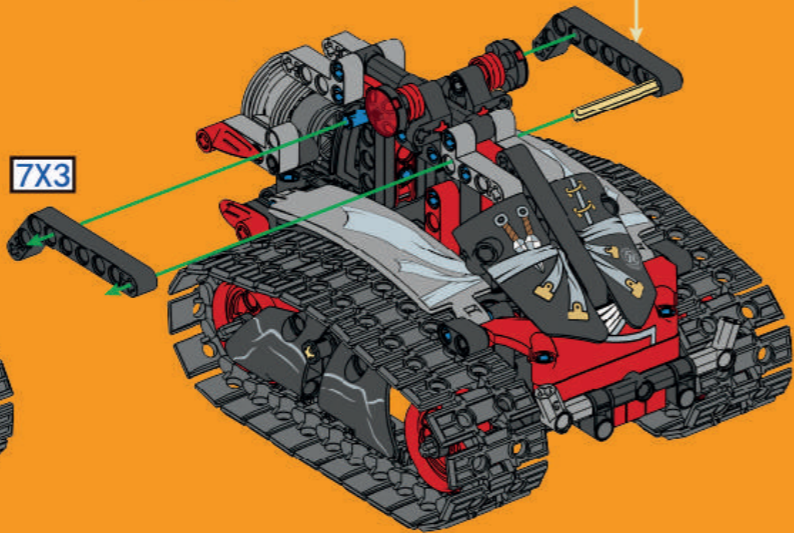

X1



X1



X1

66



X1



X1



X1

68

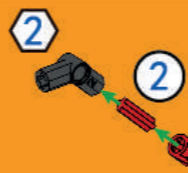

2

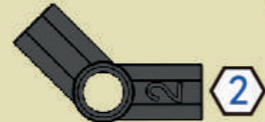

2



5

1:1



X1



X1



X1

67

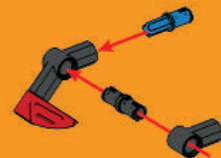

X1



X1



X1



5

X1

69

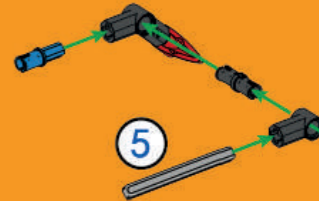

5

60

70

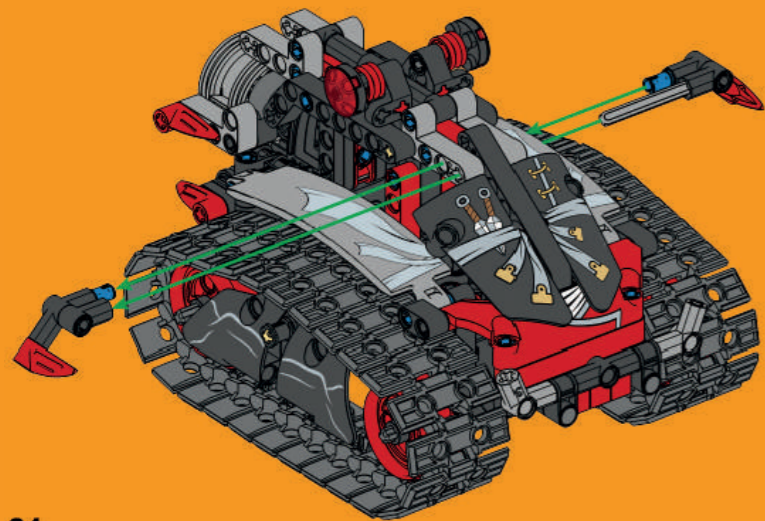

61

71



72

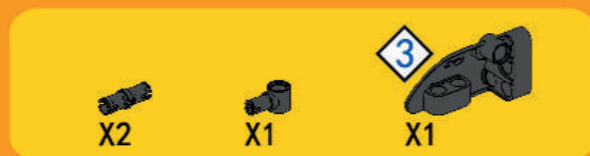

73

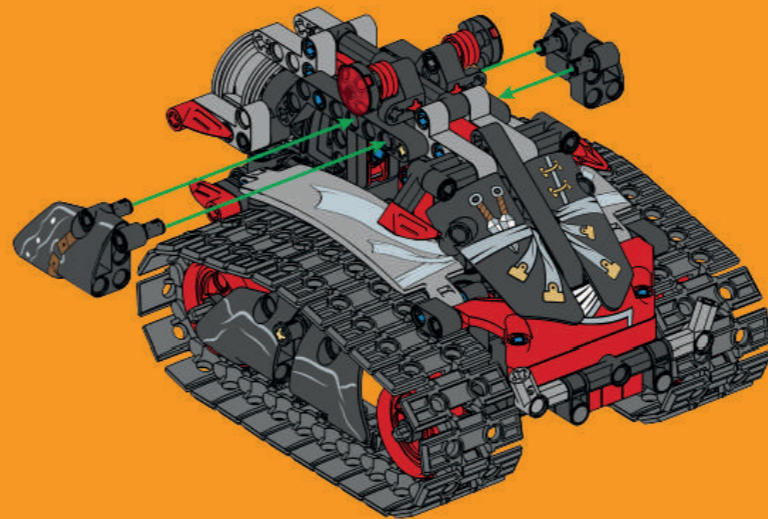

74

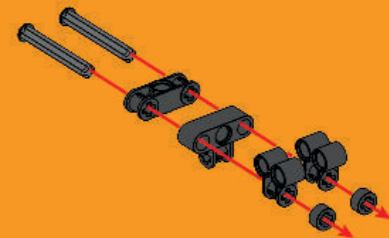

62

75

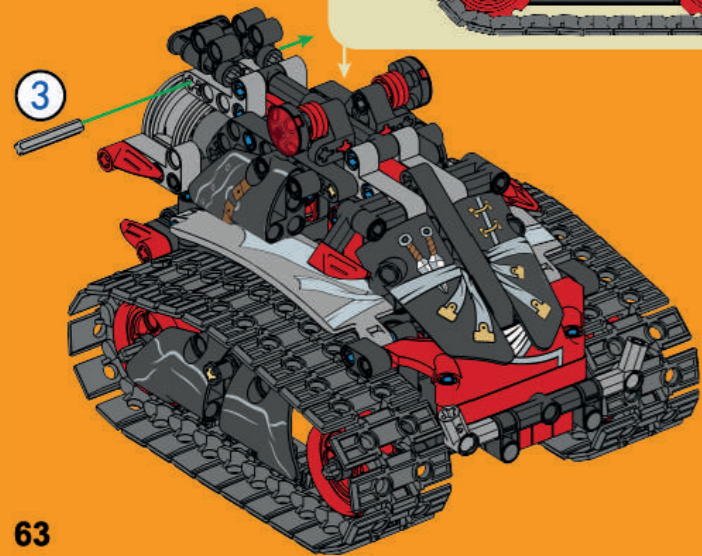

3

X1

3

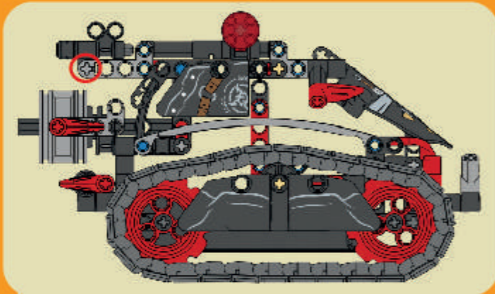

76



2

X1

X1

X1

X2

77

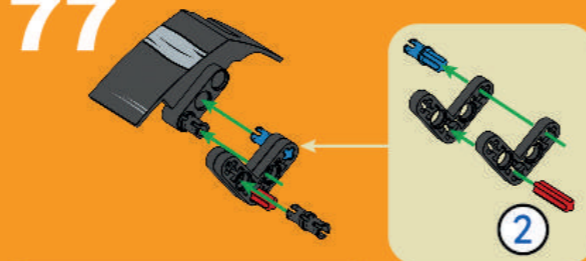

2



2



3

1:1

78

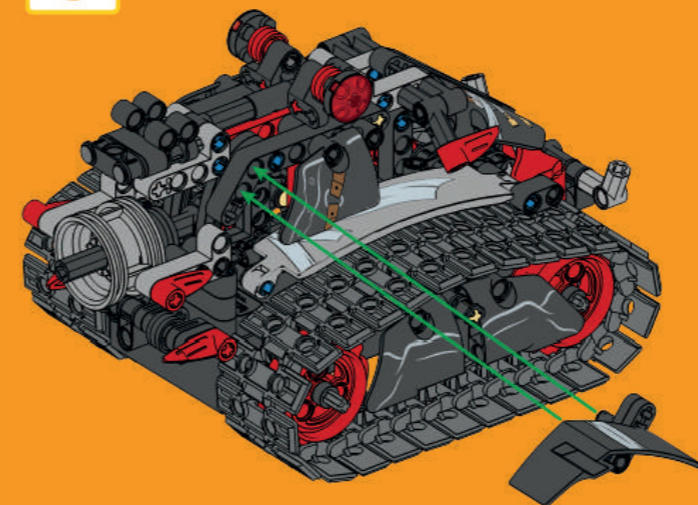

2

1:1

79



2

X1

X1

X1

X2

80



2

X1

X1

81

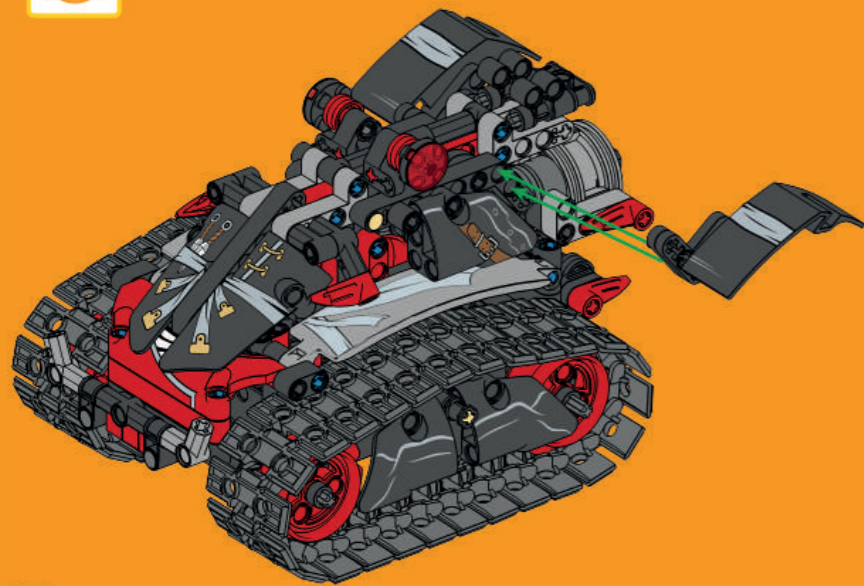

65

82

X2

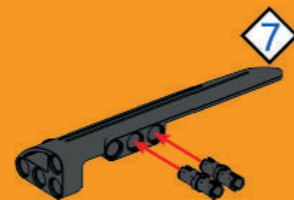
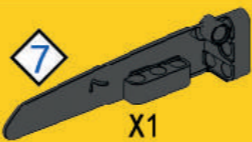

83

X2

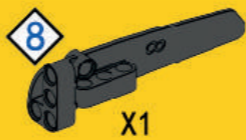

84



66

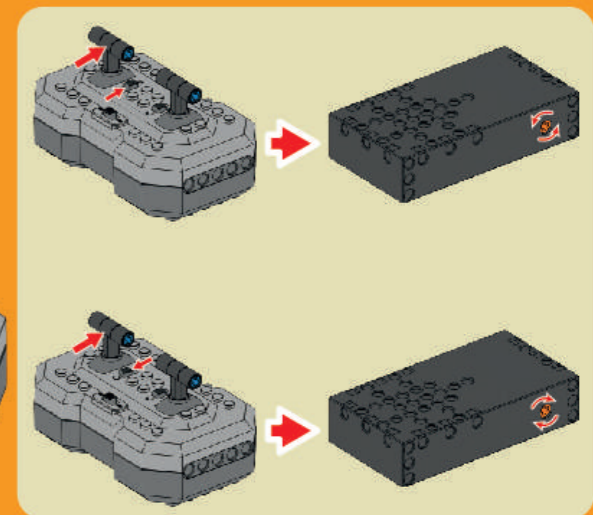
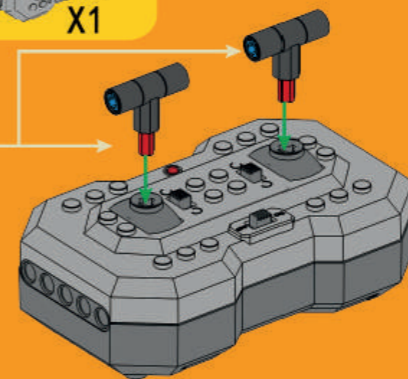
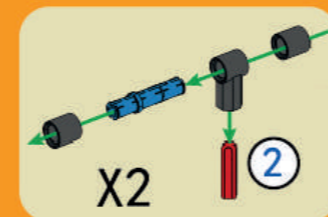
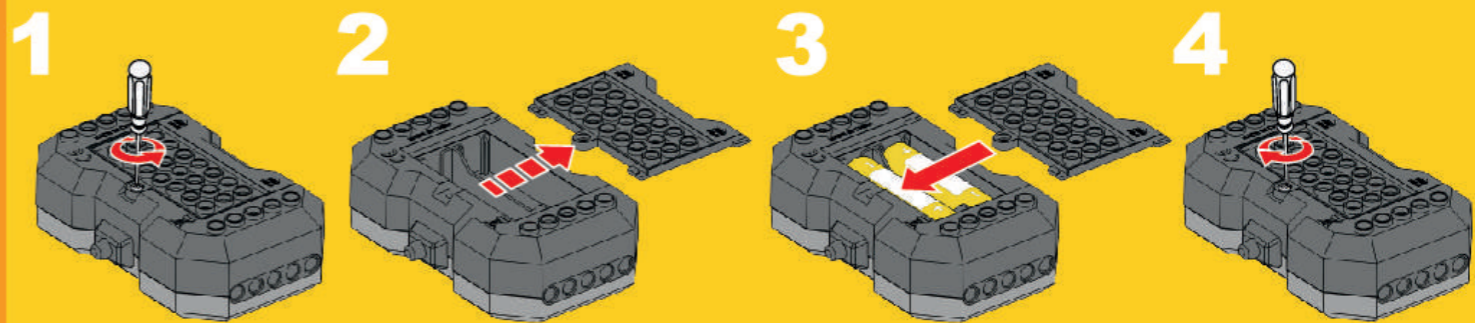
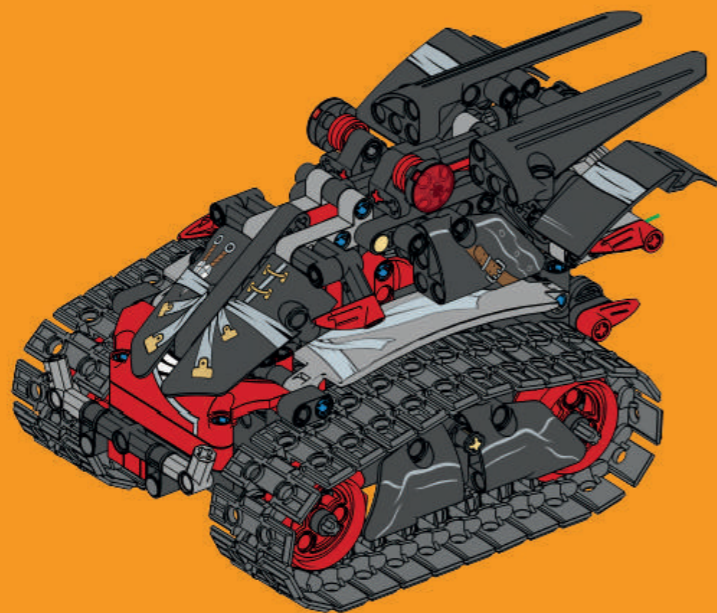

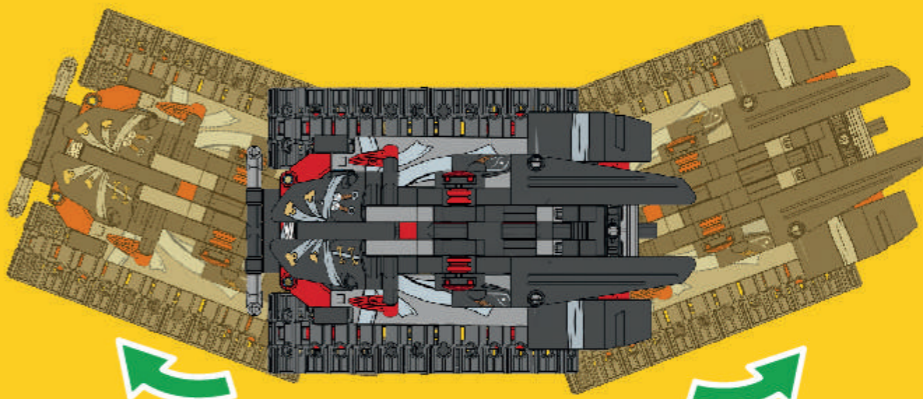
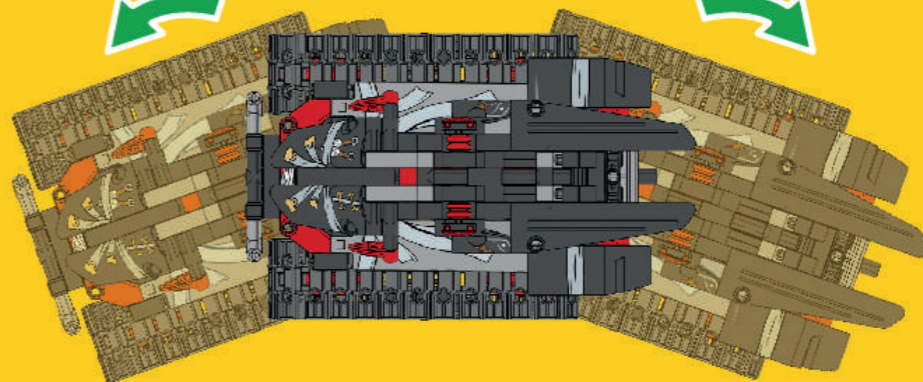
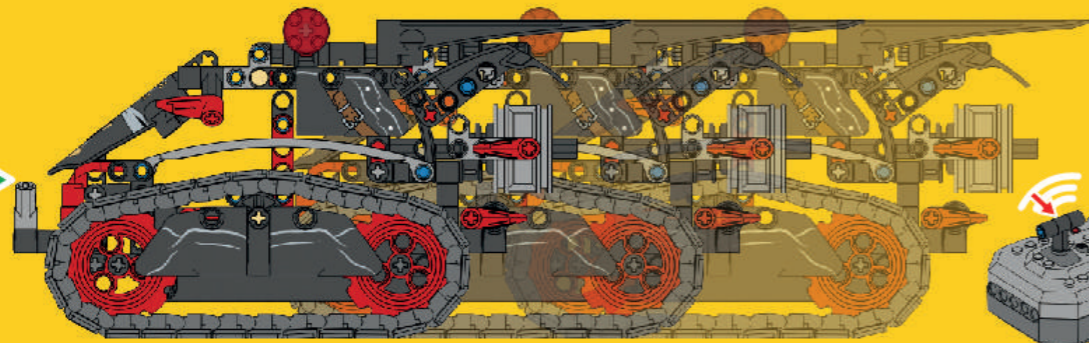
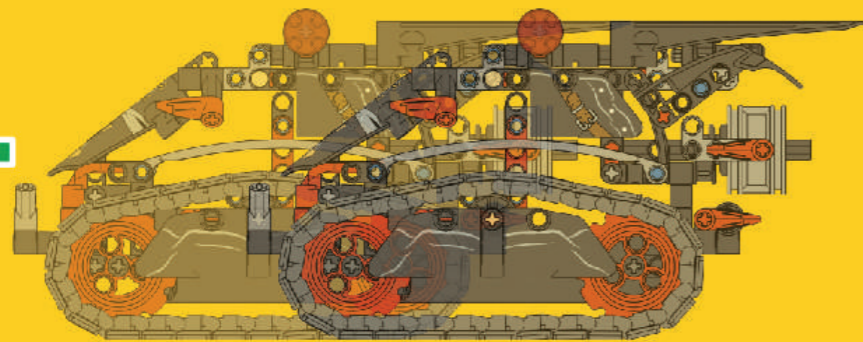

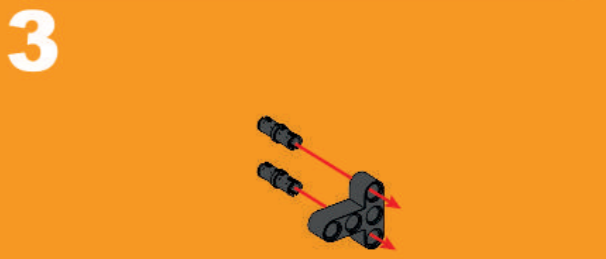
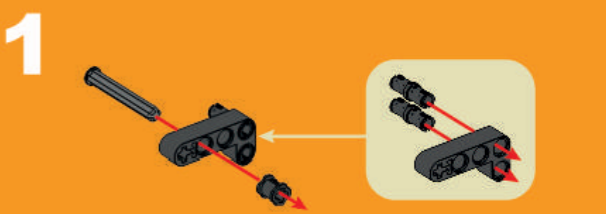
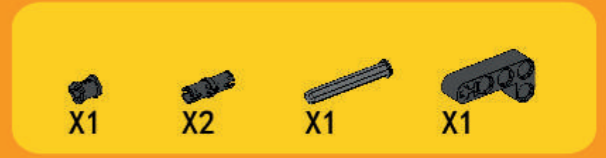
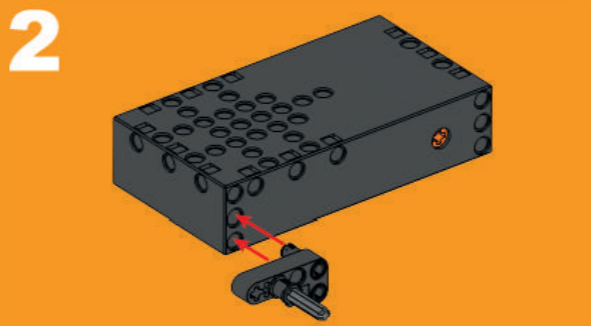
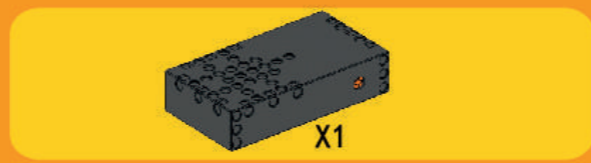
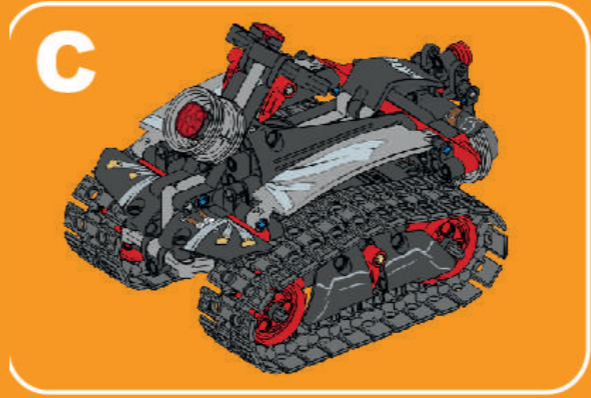
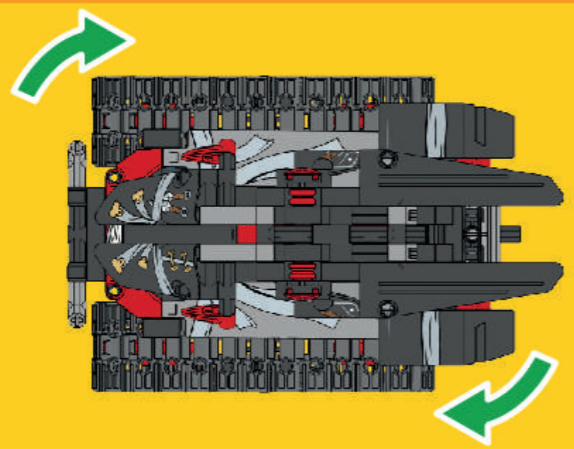
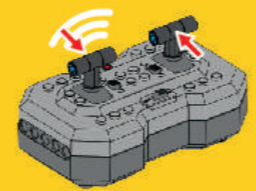
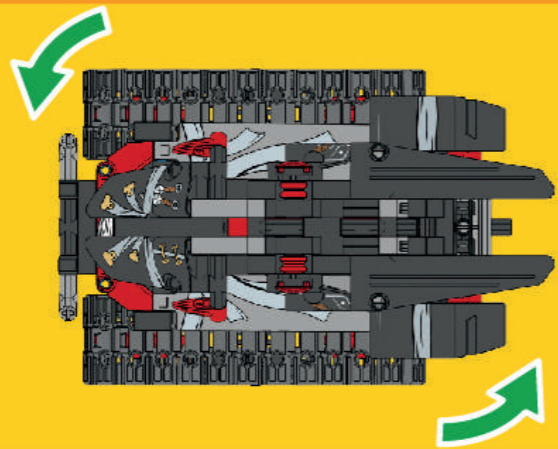

4

X1

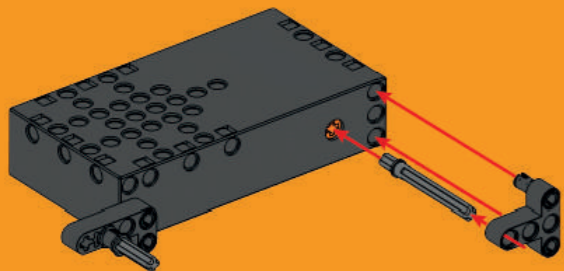

6

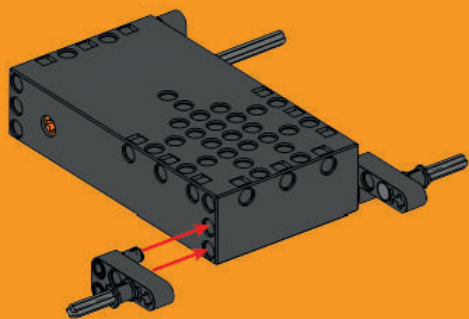

73

5

X1

X2

X1

X1

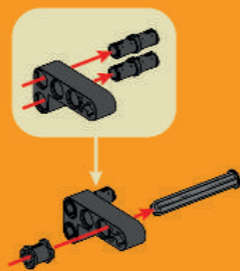

7

X2

X1

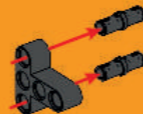

8

X1

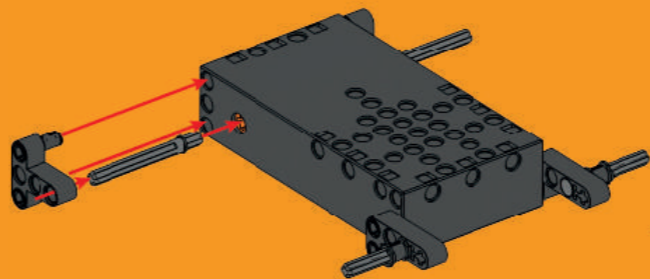

9

X4

X2

X4

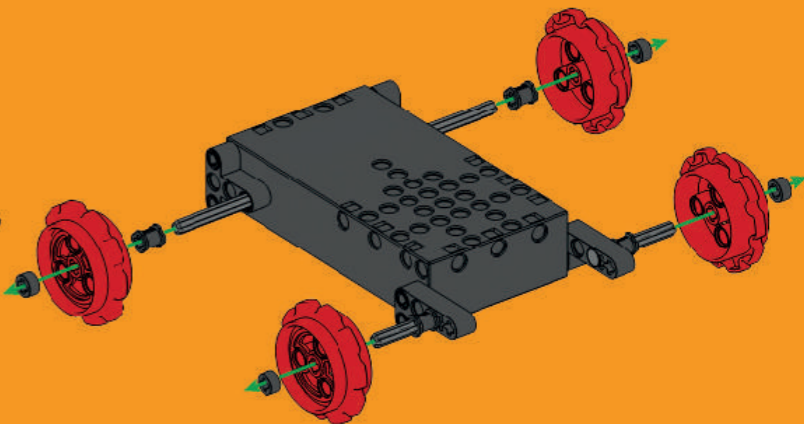

74

2

X1

X1

X1

10

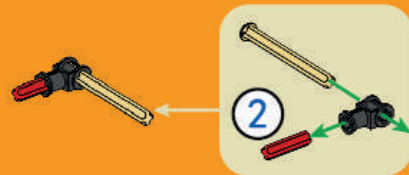

12

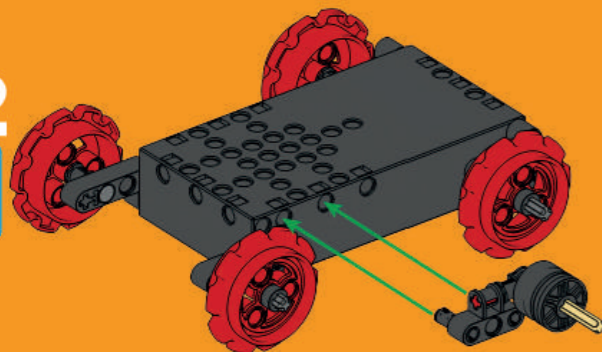

75



X2

X1

X1

11

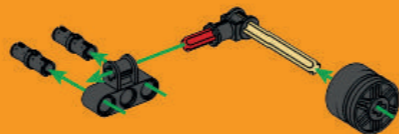

X2

X1

4

X1

3

X1

13

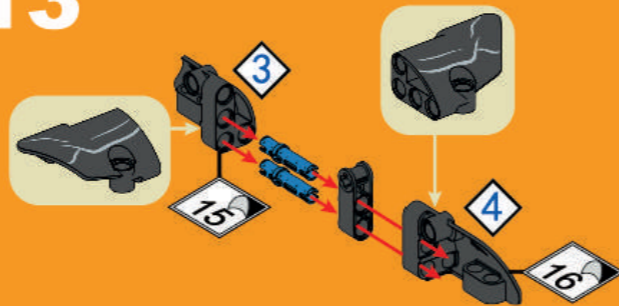

14

X1

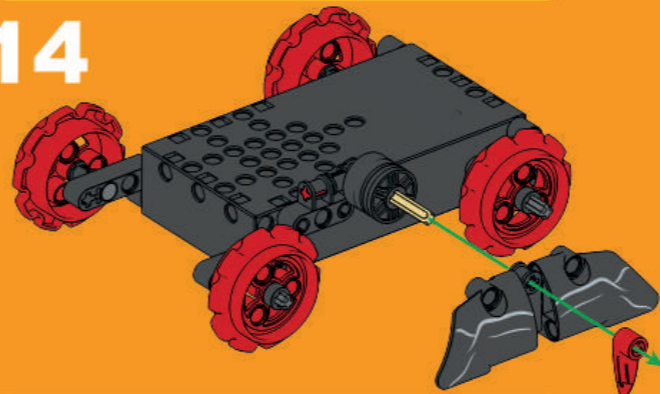

X2

X1

X1

16

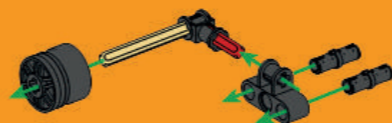

2

X1

X1

X1

15



17

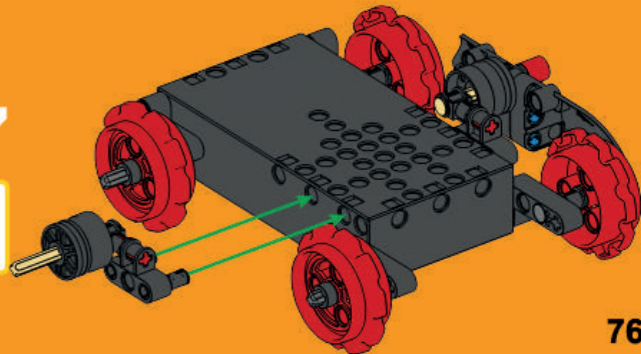

76

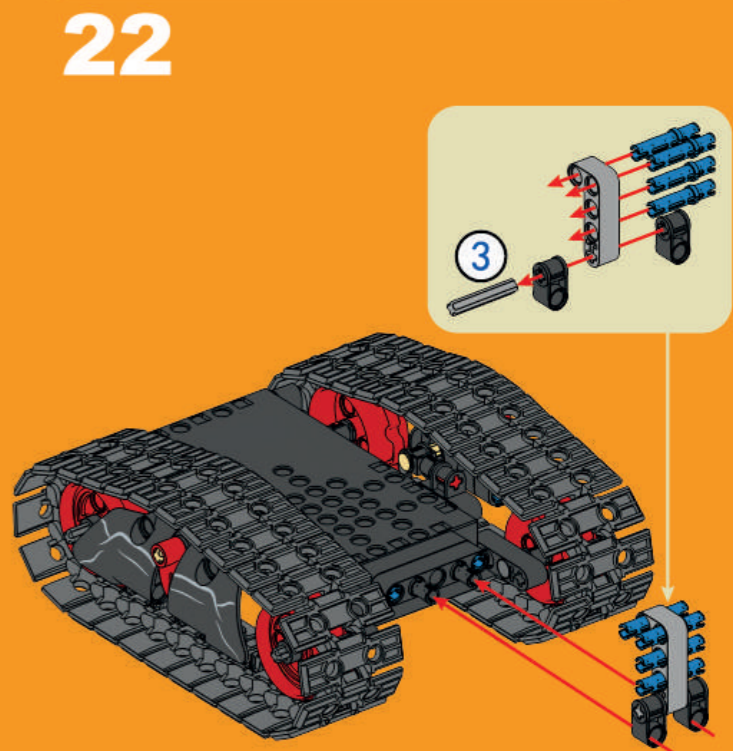
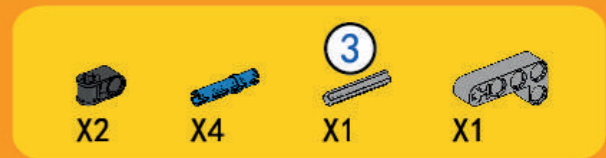
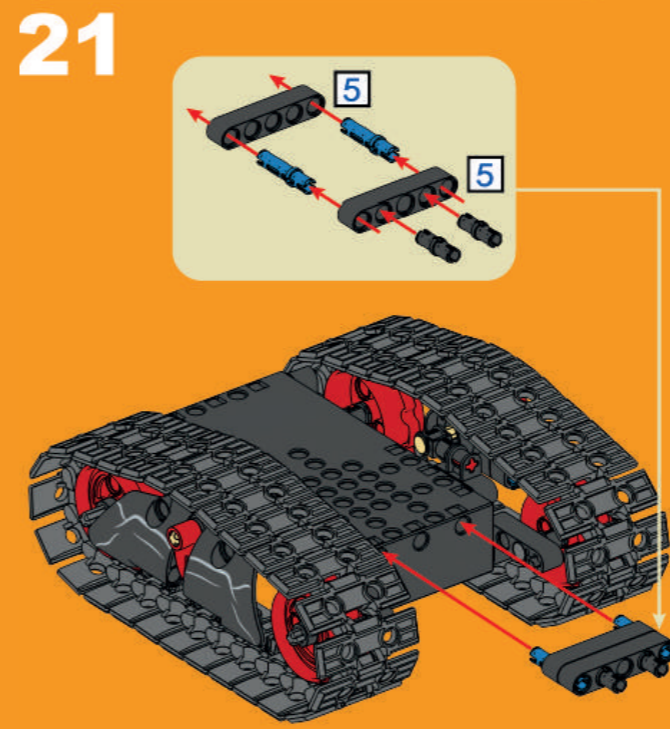
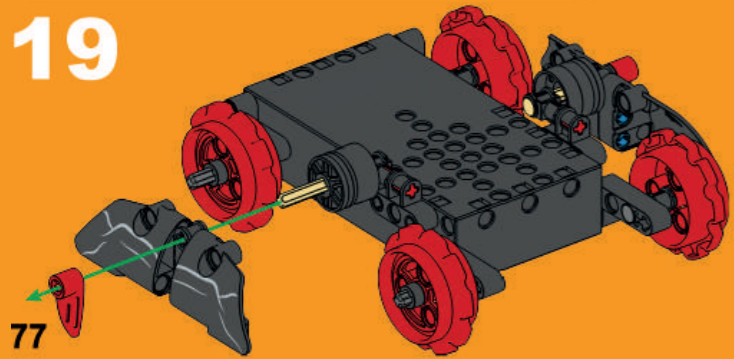
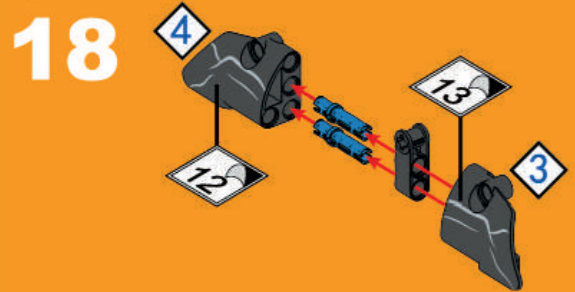



23

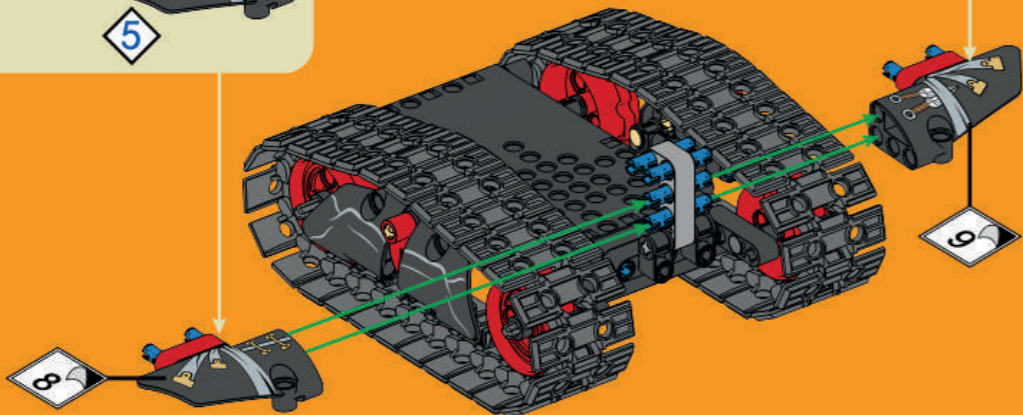
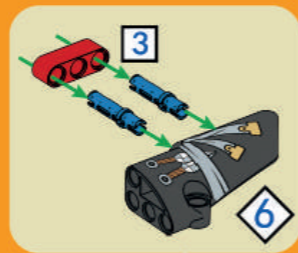
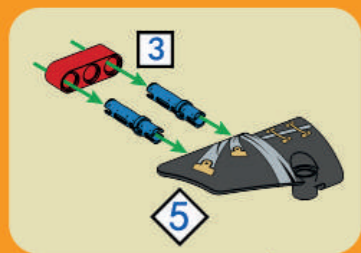

79

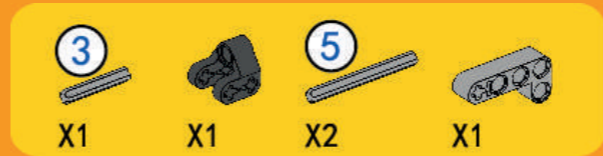

24

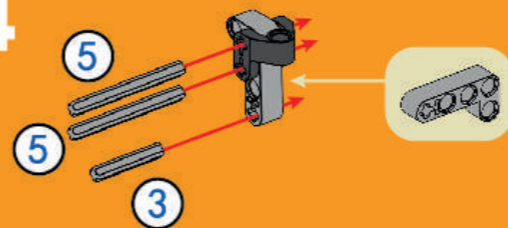

26

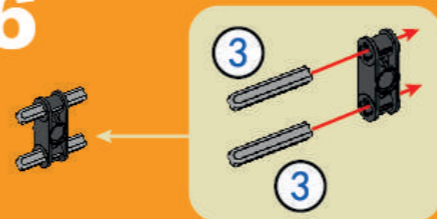

25

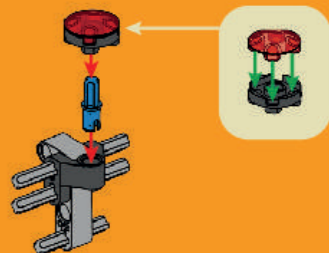

27

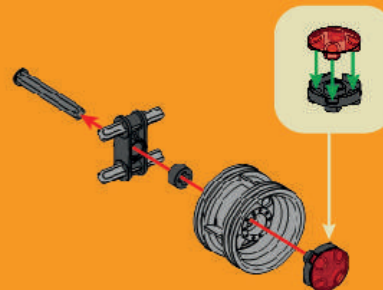

80

28

3

X1

7X3

X2

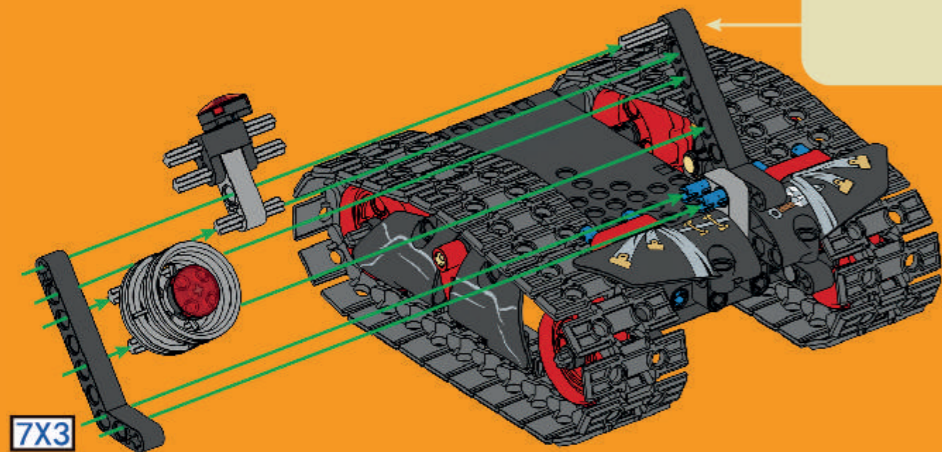
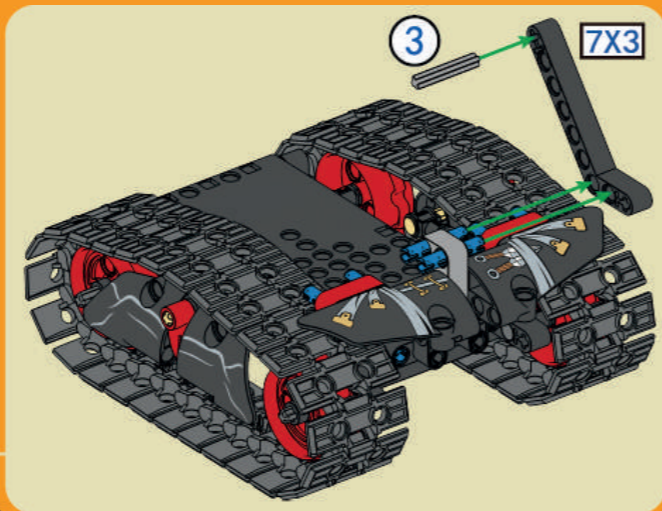

7X3

81



29

X2

X2

2

X2

2

2

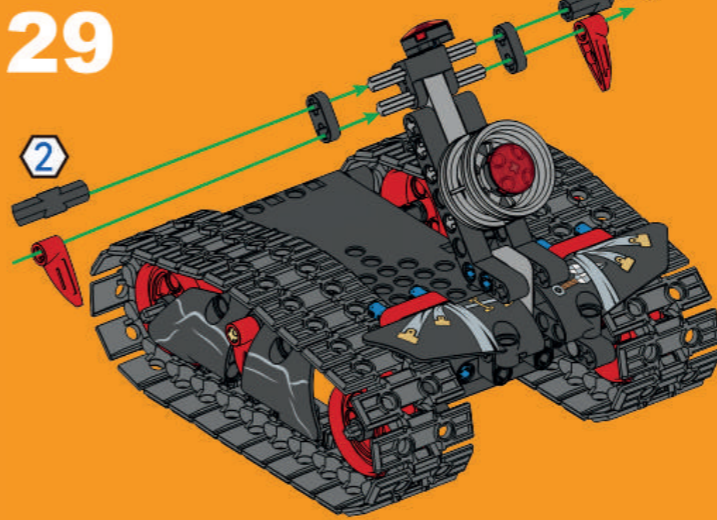
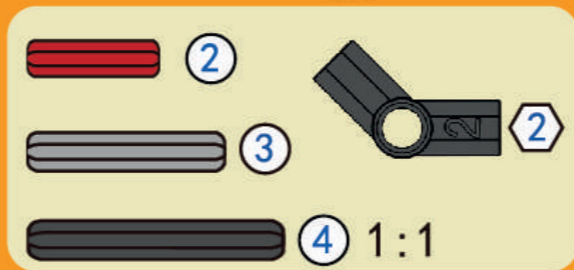

30

2

X1

3

X1

4

X1

3

X1

6

X2

3

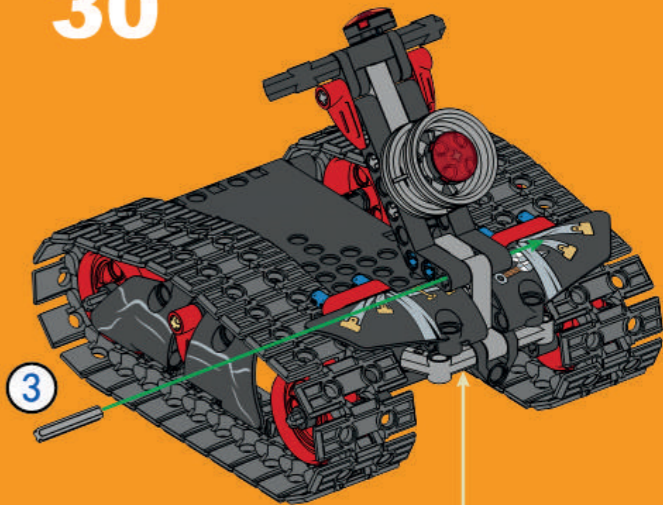
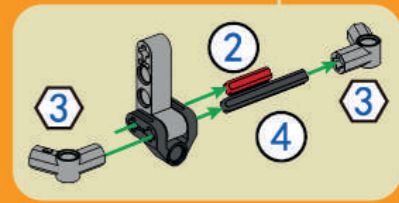

82



31

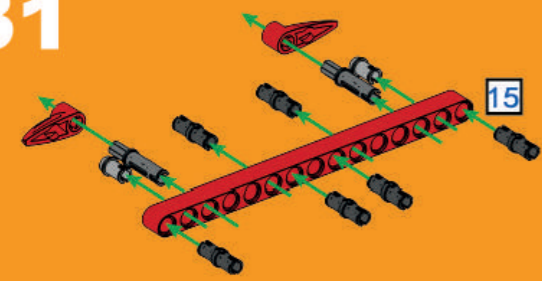

33

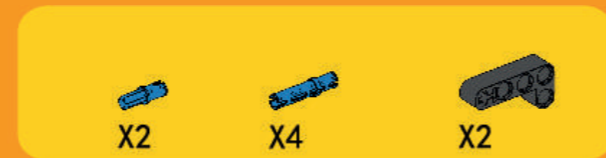
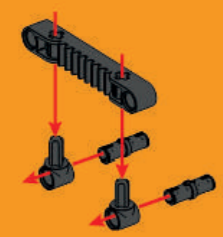

32

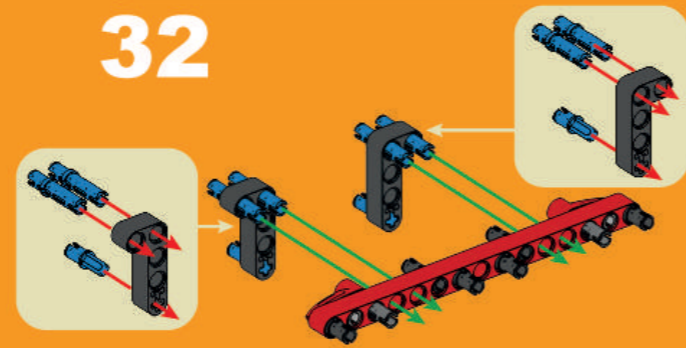

34

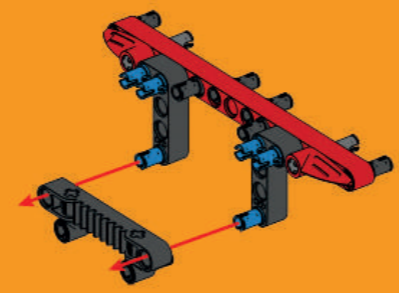

35

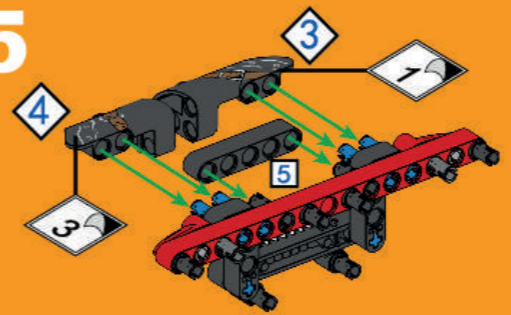

37

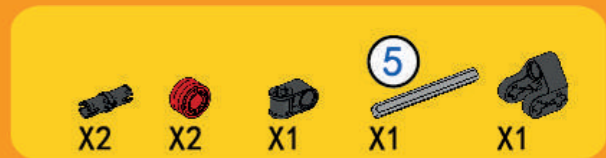
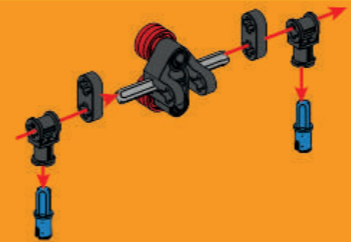

36

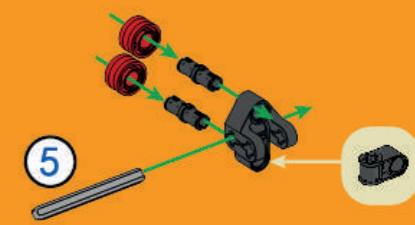

38

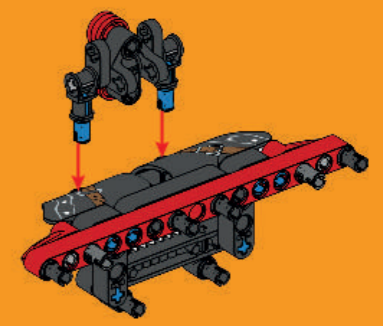

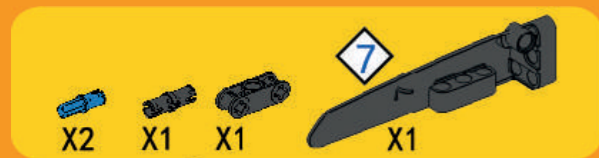

39

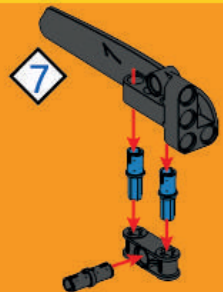

41

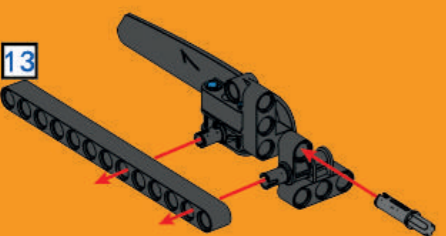

85



40

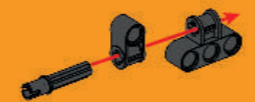

42

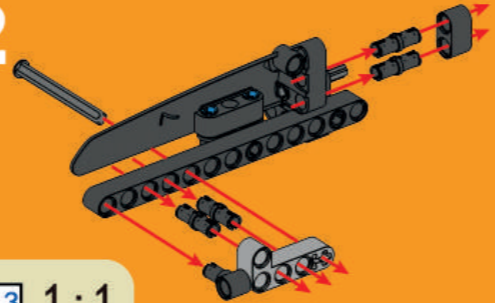

43

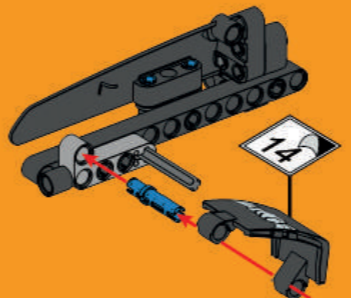

45

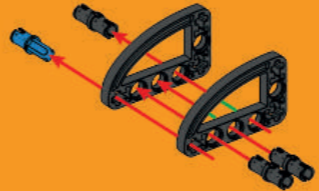

44

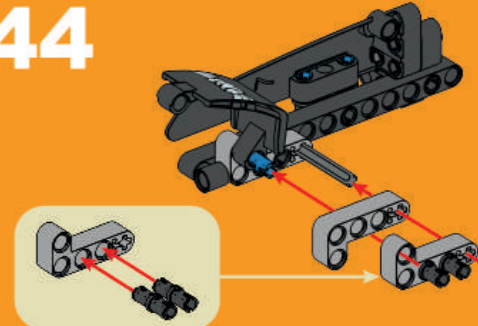

46

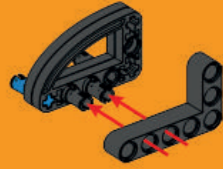

86

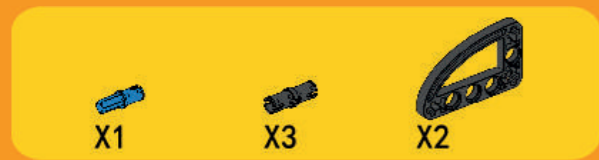

47



48

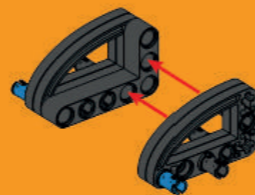

50

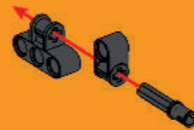

51

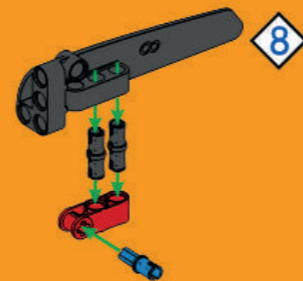

53

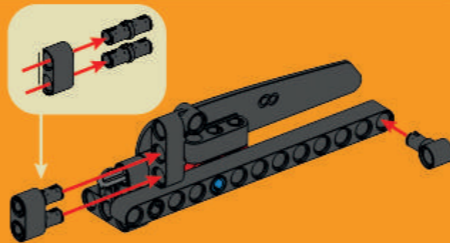

52

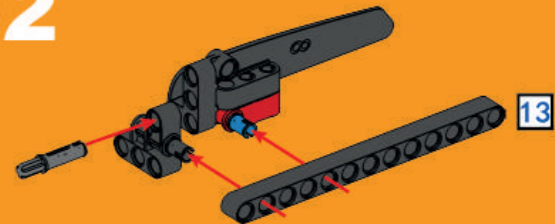

54

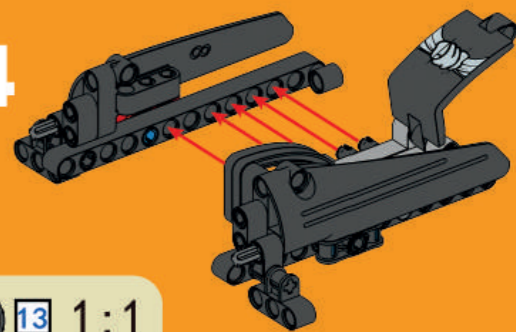

55

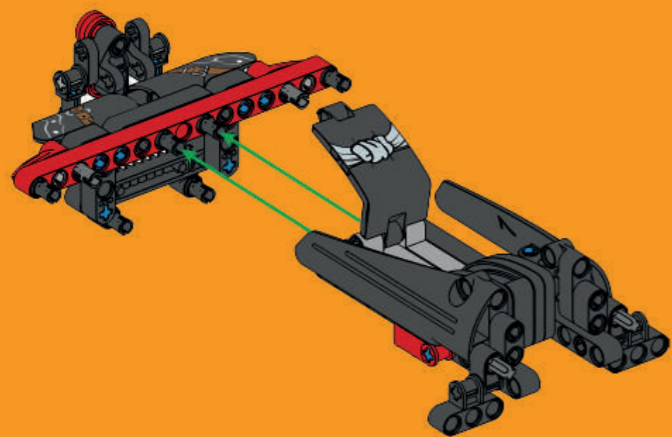

56

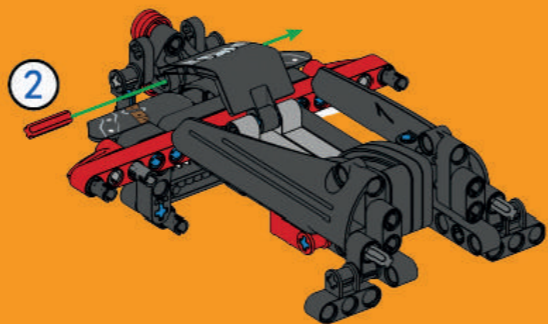

2

2

X1

57

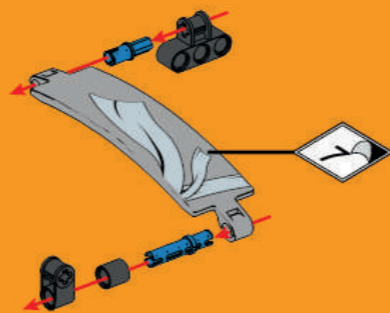

X1

X1

X1

X1

X1

X1

58

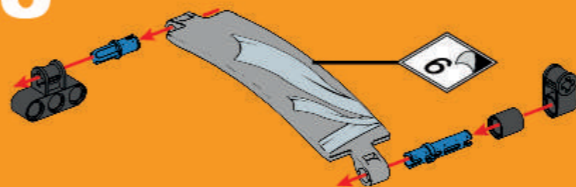

X1

X1

X1

X1

X1

X1

59

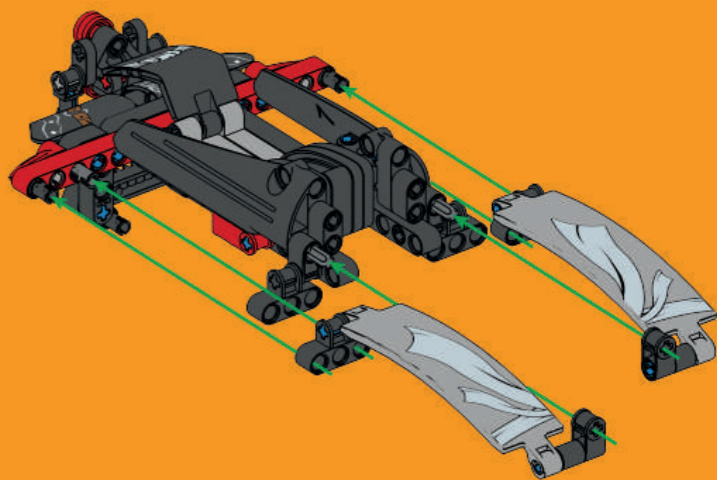

60

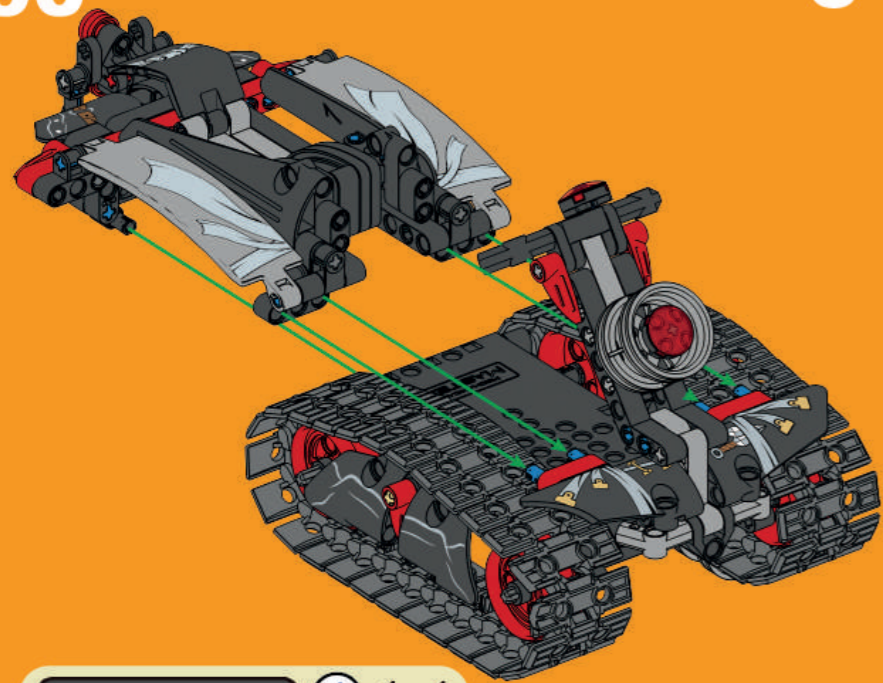

61

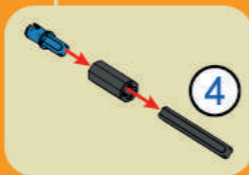
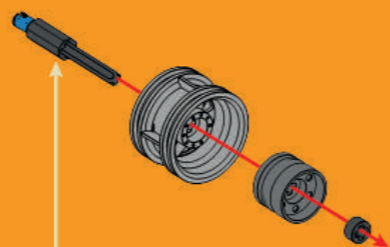

62

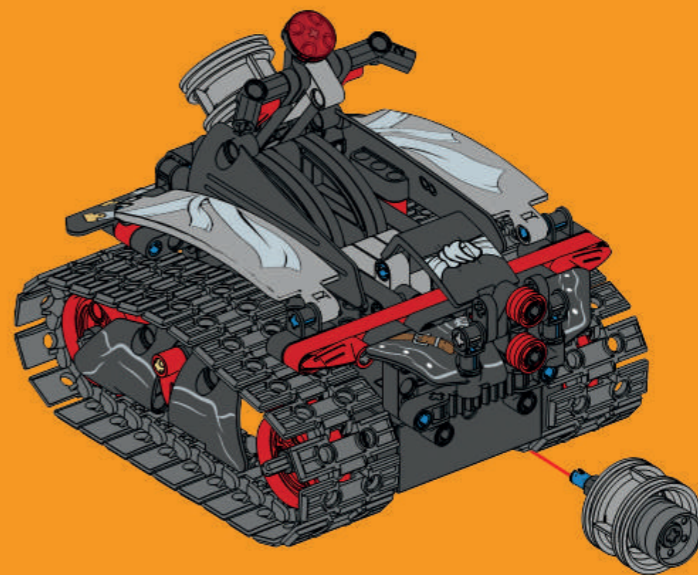

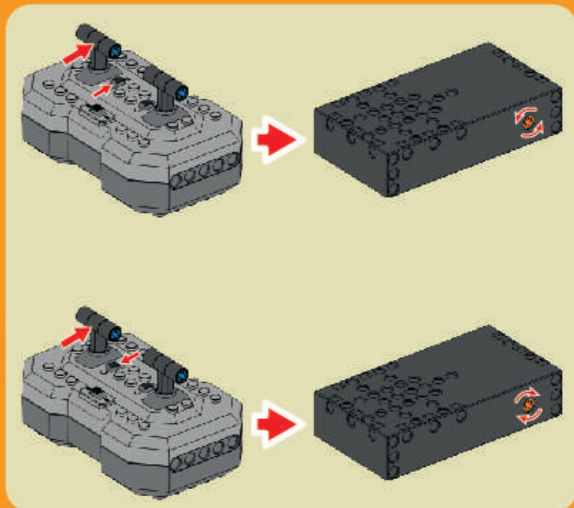
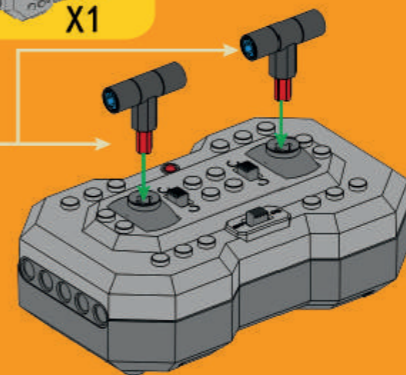
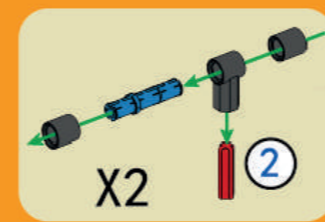
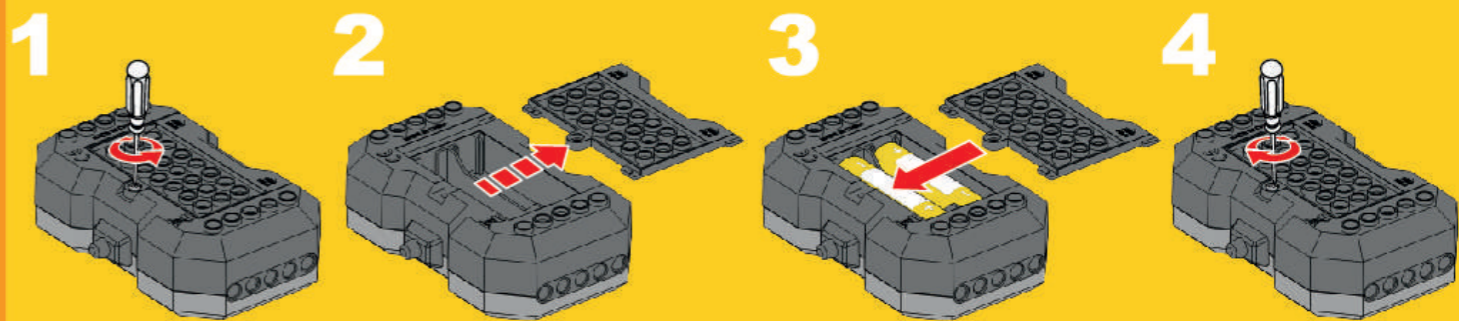
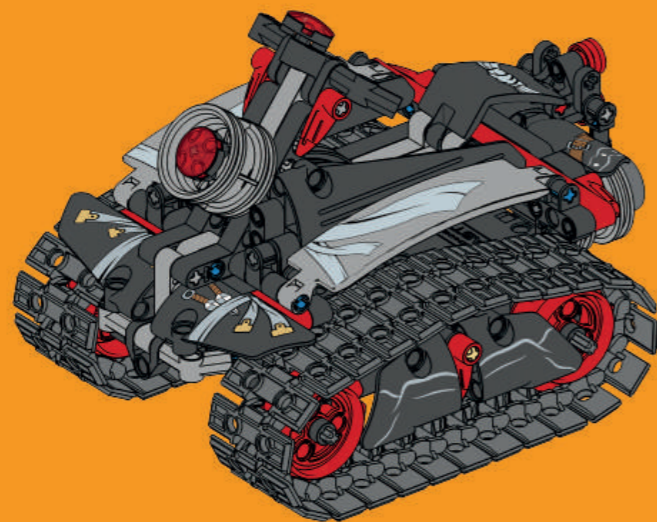

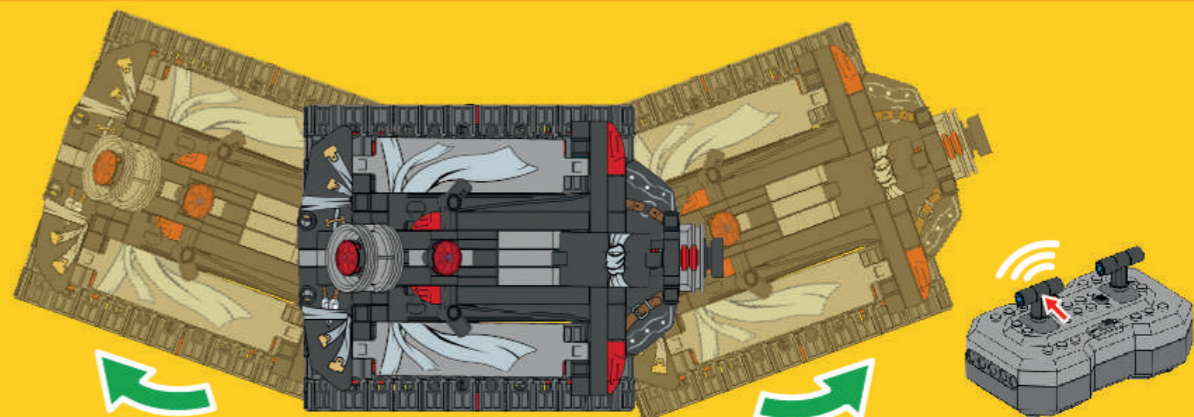
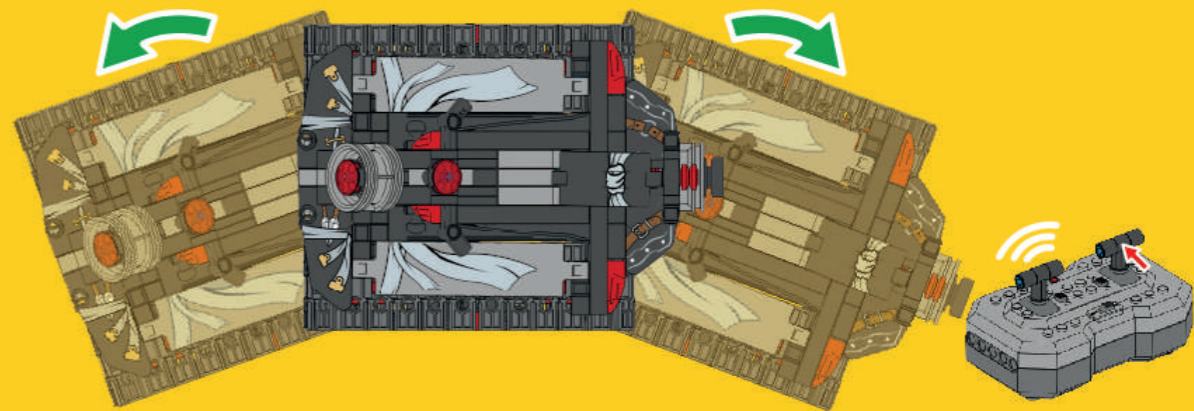
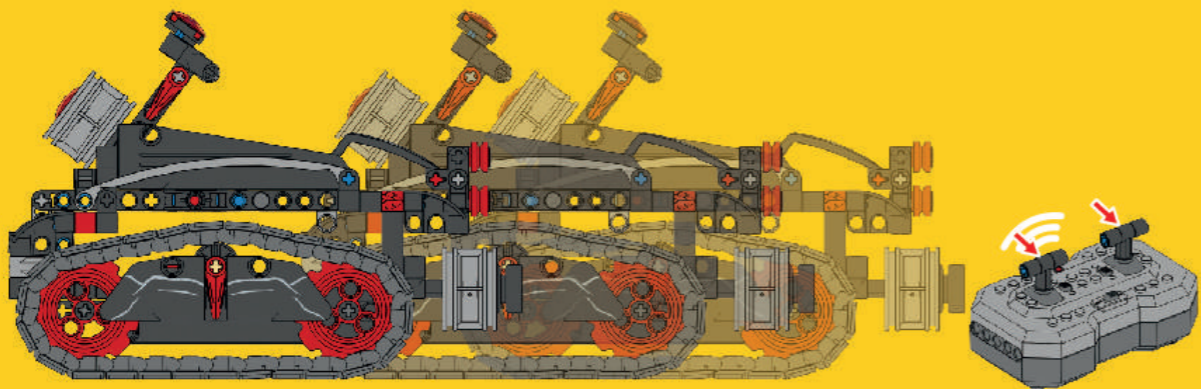
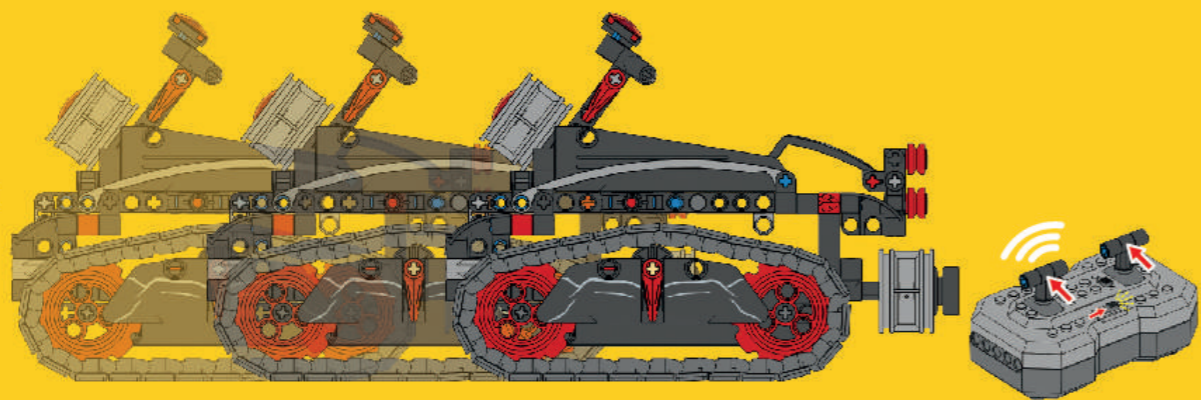

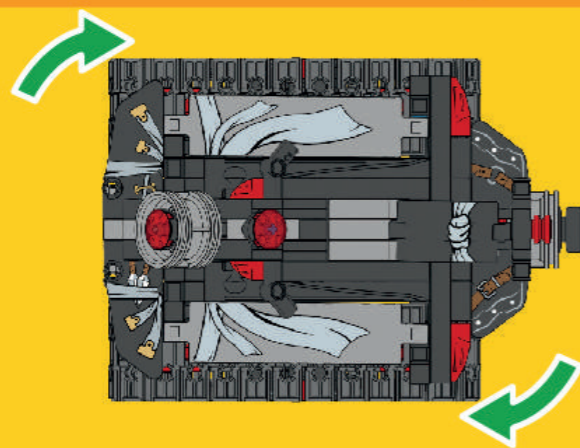
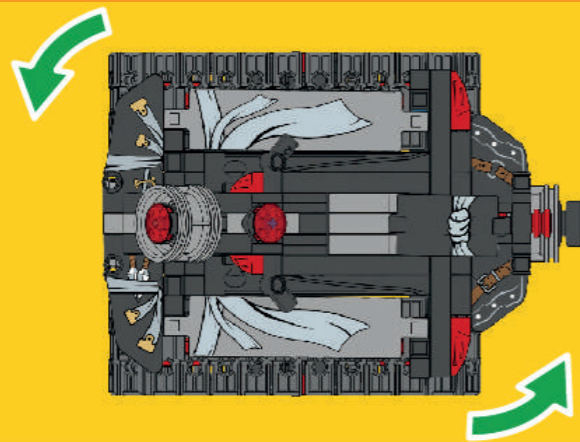

- | | | | | | | | |
|---------------------------|---------------------|----------------------|-----------------|-----------------|-----------------|-----------------|---------------------|
| 13x
22#Blue | 3x
173#Red | 1x
58#Light Grey | 6x
49#Black | 2x
189#Black | 3x
171#Black | 4x
12#Black | 2x
36#Black |
| 23x
23#Blue | 24x
24#Red | 1x
225#Red | 2x
71#Black | 2x
116#Black | 4x
102#Black | 4x
102#Black | 4x
102#Black |
| 3x
170#Sand Yellow | 2x
198#Red | 6x
117#Dark Grey | 5x
101#Black | 4x
40#Black | 4x
82#Black | 2x
193#Black | 1x
206#Black |
| 2x
188#Transparent Red | 2x
16#Red | 6x
30#Dark Grey | 4x
48#Black | 2x
42#Black | 9x
154#Black | 3x
77#Black | 1x
206#Black |
| 2x
52#Red | 6x
114#Red | 2x
74#Dark Grey | 8x
86#Black | 3x
39#Black | 6x
174#Black | 3x
78#Black | 1x
206#Black |
| 2x
28#Red | 1x
131#Red | 2x
193#Dark Grey | 9x
16#Black | 2x
17#Black | 6x
174#Black | 3x
78#Black | 1x
134#Dark Grey |
| 1x
15#Red | 1x
40#Red | 2x
215#Light Grey | 1x
177#Black | 1x
110#Black | 2x
17#Black | 4x
87#Black | 2x
104#Black |
| 1x
54#Red | 58x
55#Dark Grey | 2x
215#Light Grey | 1x
125#Black | 2x
11#Black | 6x
112#Black | 4x
87#Black | 2x
104#Black |
| 1x
53#Red | 3x
47#Light Grey | 2x
178#Black | 6x
29#Black | 3x
50#Black | 1x
11#Black | 4x
56#Black | 2x
105#Black |
| 1x
107#Red | 1x
130#Red | 1x
79#Black | 8x
46#Black | 3x
38#Black | 3x
191#Black | 4x
25#Black | 3x
28#Black |
| | 1x
172#Red | 1x
80#Black | 7x
121#Black | 1x
113#Black | 3x
72#Black | 4x
195#Black | 2x
15#Black |
| | 4x
57#Red | | 70x
9#Black | 2x
198#Black | | | |